

13

Spherical roller thrust bearings

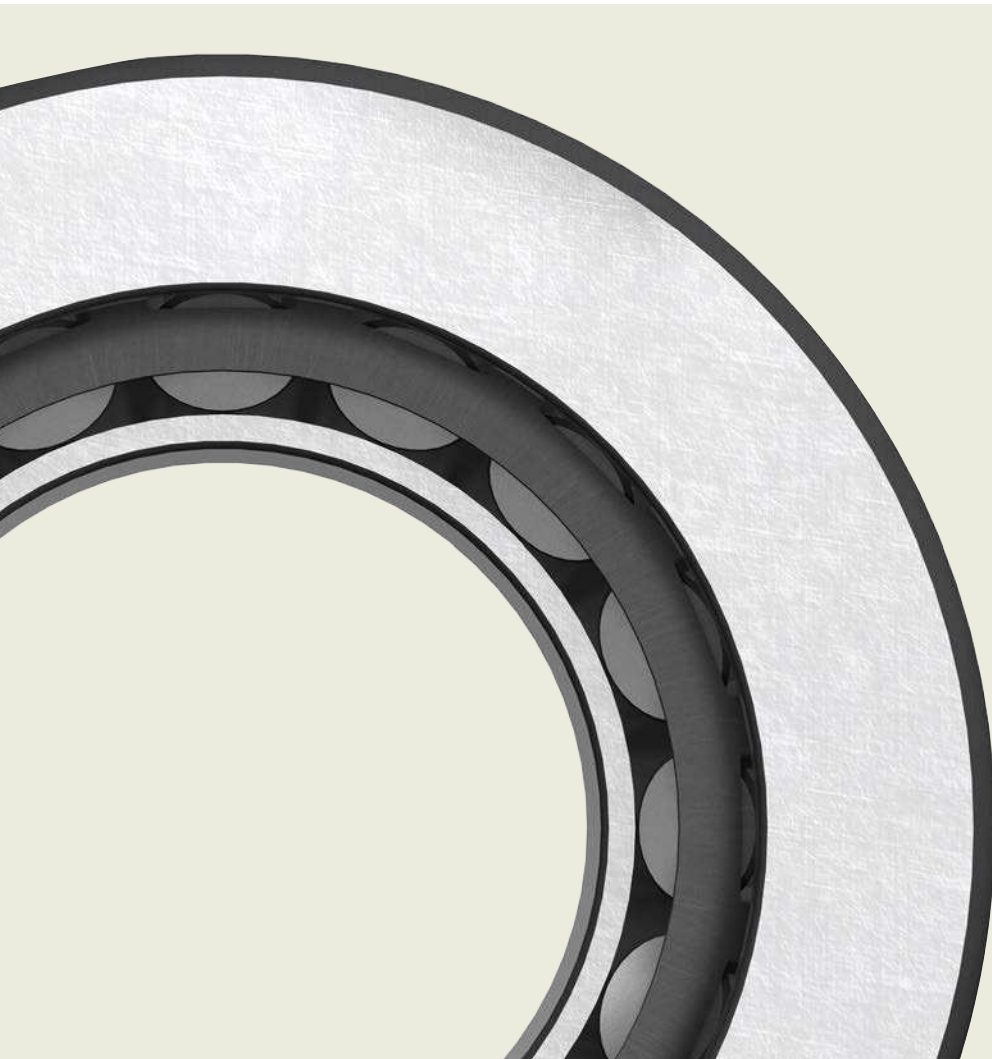

13 Spherical roller thrust bearings

Designs and variants	915		
Basic design bearings	915		
SKF Explorer bearings	915		
Cages	915		
Bearing data	916		
(Dimension standards, tolerances, permissible misalignment, friction, starting torque, power loss)			
Loads	917		
(Minimum load, equivalent dynamic bearing load, equivalent static bearing load)			
Temperature limits	918		
Permissible speed	918		
Design considerations	918		
Abutment dimensions	918		
Recessed housing bore for bearings with a stamped steel cage	918		
Axial clearance in bearing arrangements	918		
Lubrication	919		
Pumping effect in oil lubricated applications	919		
Mounting	920		
Designation system	921		
Product table		Other spherical roller thrust bearings	
13.1 Spherical roller thrust bearings	922	NoWear coated bearings	1059

13 Spherical roller thrust bearings

More information

General bearing knowledge	17
Bearing selection process	59
Lubrication	109
Bearing interfaces	139
Seat tolerances for standard conditions	148
Sealing, mounting and dismounting	193

Mounting instructions for individual bearings → skf.com/mount

SKF bearing maintenance handbook ISBN 978-91-978966-4-1

SKF spherical roller thrust bearings have specially designed raceways and asymmetrical rollers. The bearings can accommodate axial loads acting in one direction and simultaneously acting radial loads. The load is transmitted between the raceways via the rollers at an angle to the bearing axis, while the flange guides the rollers (**fig. 1**).

Bearing features

- **High load carrying capacity**
The large number of rollers, which have an optimum conformity with the washer raceways, enables the bearings to accommodate heavy axial and simultaneously acting radial loads.
- **Accommodate misalignment**
SKF spherical roller thrust bearings are self-aligning and can accommodate misalignment (**fig. 2**).

- **Separable design**
SKF spherical roller thrust bearings are separable, making it possible to mount and dismount the housing washer separately from the shaft washer and roller and cage assembly. In addition this facilitates maintenance inspections.
- **High speed capability**
The cage designs and the optimum conformity of the rollers with the washer raceways make the bearings suitable for relatively high speeds.
- **Long service life**
The special roller profile reduces edge stresses at the roller/raceway contact.
- **Low friction**
The optimized roller end / flange contact keeps frictional heat at low level, even at high speeds.

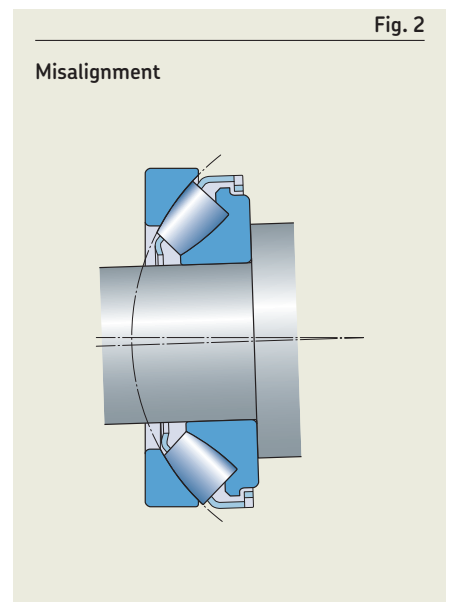
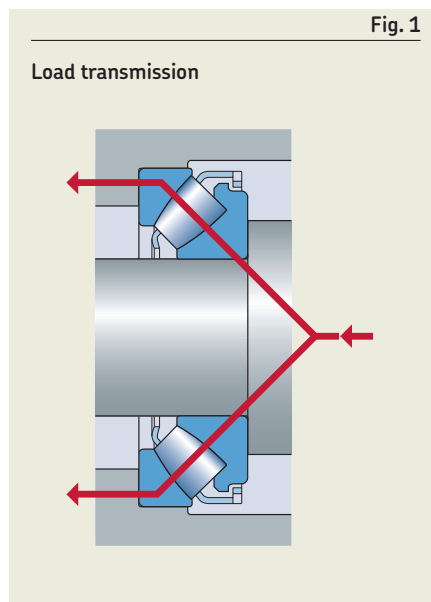

Designs and variants

Basic design bearings

Depending on their series and size, SKF spherical roller thrust bearings are manufactured to two basic designs (fig. 3). Their cage forms a non-separable unit with the shaft washer and rollers.

Bearings with no designation suffix (e.g. 29272)

- are fitted with a machined brass prong-type cage as standard

E design bearings (designation suffix E)

- have larger rollers and an optimized internal design for increased load carrying capacity
- are fitted with one of the following cages, depending on bearing size:
 - size ≤ 68 → stamped steel window-type cage
 - size ≥ 72 → machined metal prong-type cage

SKF Explorer bearings

For information, refer to [page 7](#).

Cages

Cages in SKF spherical roller thrust bearings are an integral part of the bearing internal design. All SKF spherical roller thrust bearings contain a strong metal cage. This enables them to tolerate high temperatures and operate with all lubricants.

For additional information about the suitability of cages, refer to *Cages*, [page 187](#).

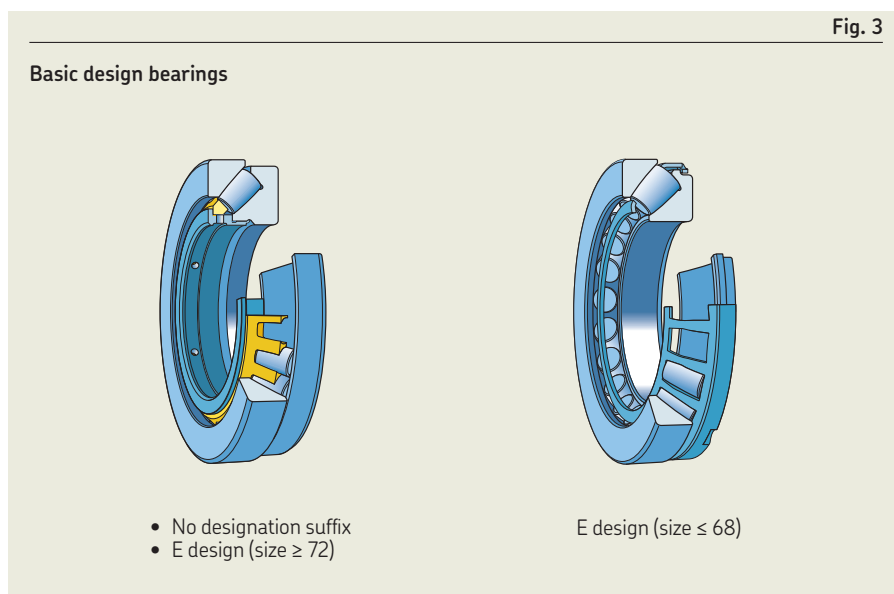

Bearing data

Dimension standards	Boundary dimensions: ISO 104
Tolerances	Normal Total height H: <ul style="list-style-type: none"> for basic design bearings, tolerance at least 50% tighter than ISO standard for SKF Explorer bearings, tolerance 75% tighter than ISO standard
For additional information → page 35	Values: ISO 199 (table 10, page 46)
Permissible misalignment	The permissible misalignment is reduced as the load increases. Guideline values for rotating shaft applications: table 1 . Whether these values can be fully exploited depends on the design of the bearing arrangement, the external sealing design, etc. For applications with a rotating housing washer, or where the direction of misalignment is not constant relative to the housing washer, additional sliding may occur in the bearing and misalignment should be $< 0,1^\circ$.
Friction, starting torque, power loss	→ skf.com/bearingcalculator For temperature and/or cooling requirement calculations for large bearings ($d_m > 400 \text{ mm}$) ¹⁾ , vertical shafts and fully submerged conditions, contact the SKF application engineering service.

¹⁾ d_m = bearing mean diameter [mm]
= $0,5 (d + D)$

Table 1

Permissible angular misalignment for rotating shafts

Bearing series	Permissible misalignment where bearing load P_0 ¹⁾		
	$< 0,05 C_0$	$\geq 0,05 C_0$	$> 0,3 C_0$
–	°		
292(E)	2	1,5	1
293(E)	2,5	1,5	0,3
294(E)	3	1,5	0,3

¹⁾ Refer to *Equivalent static bearing load*.

Loads

<p>Minimum load</p> <p>The minimum load requirements can be ignored for bearings operating at the relatively low speeds shown within the green area in diagram 1, page 919.</p> <p>For operating speeds outside the green area use:</p> $F_{am} = C_r F_r + A \left(\frac{n}{1\ 000} \right)^2 + F_{lub}$ $v n \geq 2\ 000 \rightarrow F_{lub} = \frac{2 \times 10^{-9} f_0 (v n)^{2/3} [0,5 (d + D)]^3}{d}$ $v n < 2\ 000 \rightarrow F_{lub} = \frac{3,2 \times 10^{-7} f_0 [0,5 (d + D)]^3}{d}$ <p>For additional information → page 106</p>	<p>Symbols</p> <p>A minimum load factor (product table, page 922)</p> <p>C_r load factor = 1,8 for 292 series = 2,0 for 293 series = 2,2 for 294 series</p> <p>D bearing outside diameter [mm]</p> <p>d bearing bore diameter [mm]</p> <p>f_0 factor for lubrication method For oil bath lubrication with a horizontal shaft and for grease lubrication: = 3 for 292 series = 3,5 for 293 series = 4 for 294 series For oil bath lubrication with a vertical shaft and for oil jet lubrication: = 6 for 292 series = 7 for 293 series = 8 for 294 series</p> <p>F_{am} minimum axial load [kN]</p> <p>F_{lub} axial load required to overcome lubricant drag [kN]</p> <p>F_r radial load [kN]</p> <p>n rotational speed [r/min]</p> <p>P equivalent dynamic bearing load [kN]</p> <p>P_0 equivalent static bearing load [kN]</p> <p>X calculation factor = 1,1 for 292 series = 1,2 for 293 series = 1,3 for 294 series</p> <p>X_0 calculation factor = 2,5 for 292 series = 2,7 for 293 series = 2,9 for 294 series</p> <p>v actual operating viscosity of the lubricant [mm²/s]</p>
<p>Equivalent dynamic bearing load</p> <p>For additional information → page 91</p>	<p>$F_r \leq 0,55 F_a$ and:</p> <ul style="list-style-type: none"> if run-out in the bearing arrangement does not affect the load distribution in the spherical roller thrust bearing → $P = 0,88 (F_a + X F_r)$ if run-out in the bearing arrangement affects the load distribution in the spherical roller thrust bearing (e.g. the run-out of another bearing that induces radial forces) → $P = F_a + X F_r$ <p>$F_r > 0,55 F_a \rightarrow$ Use an additional bearing, which accommodates the radial load.</p>
<p>Equivalent static bearing load</p> <p>For additional information → page 105</p>	<p>$F_r \leq 0,55 F_a \rightarrow P_0 = F_a + X_0 F_r$</p> <p>$F_r > 0,55 F_a \rightarrow$ Use an additional bearing, which accommodates the radial load.</p>

Temperature limits

The permissible operating temperature for spherical roller thrust bearings can be limited by:

- the dimensional stability of the bearing washers
- the lubricant

Where temperatures outside the permissible range are expected, contact SKF.

Bearing washers

The washers of SKF spherical roller thrust bearings are heat stabilized up to 200 °C (390 °F).

Lubricants

For temperature limits of SKF greases, refer to *Selecting a suitable SKF grease*, page 116.

When using lubricants not supplied by SKF, temperature limits should be evaluated according to the SKF traffic light concept (page 117).

Permissible speed

The speed ratings in the [product table](#), page 922, indicate:

- the **reference speed**, which enables a quick assessment of the speed capabilities from a thermal frame of reference
- the **limiting speed**, which is a mechanical limit that should not be exceeded unless the bearing design and the application are adapted for higher speeds

For additional information, refer to *Operating temperature and speed*, page 130.

Design considerations

Abutment dimensions

The abutment dimensions $d_{a\ min}$ and $D_{a\ max}$ listed in the [product table](#), page 922, apply for axial bearing loads $F_a \leq 0,1 C_0$.

For heavier bearing loads, it may be necessary to support the shaft and housing washers over their entire side faces ($d_a = d_1$ and $D_a = D_1$).

For heavy loads, where $P > 0,1 C_0$, the shaft washer bore must be fully supported by the shaft, preferably by an interference fit. Even the housing washer should be radially supported (fig. 4).

For additional information about dimensioning washer supports, contact the SKF application engineering service.

Recessed housing bore for bearings with a stamped steel cage

For bearings fitted with a stamped steel window-type cage, the housing bore must be recessed (fig. 5) to prevent the cage from

contacting the housing during possible misalignment. SKF recommends the following guideline values for the recess diameter:

- $D + 15\ \text{mm}$ for bearings with an outside diameter $D \leq 380\ \text{mm}$
- $D + 20\ \text{mm}$ for bearings with an outside diameter $D > 380\ \text{mm}$

Axial clearance in bearing arrangements

SKF spherical roller thrust bearings in face-to-face or back-to-back arrangements should be preloaded. However, at the relatively low speeds shown within the green area in [diagram 1](#), the application can be designed to operate with a small axial clearance. For these applications, bearings with a modified shaft washer (designation suffix VU029) should be used. Small axial clearance enables simple and cost-effective bearing arrangements to be used, e.g. for horizontal shaft applications at relatively low speeds, as no external preload is necessary.

For additional information about bearing arrangements with axial clearance, contact the SKF application engineering service.

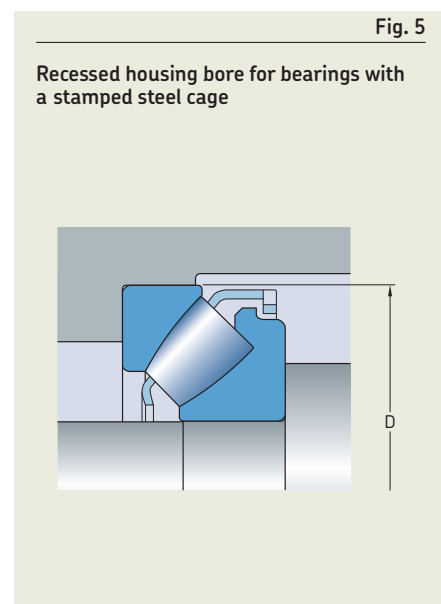
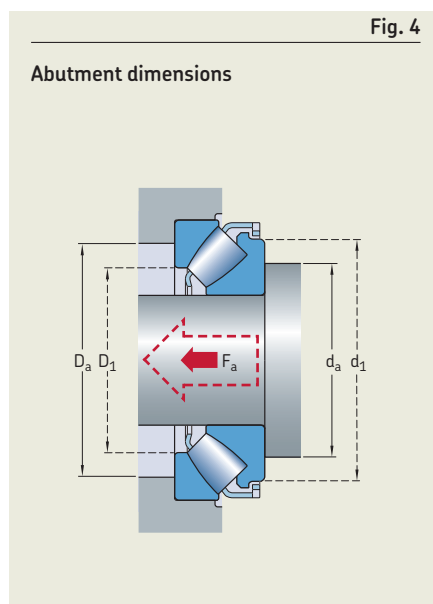

Lubrication

Generally, SKF spherical roller thrust bearings can be lubricated with oil or grease containing EP additives.

Where lubricating with grease, the roller end / flange contacts must be supplied with an adequate amount of grease. Make sure to use a grease with high oil bleeding, such as SKF LGWM 1, LGWM 2 or LGEP 2 (*Selecting a suitable SKF grease, page 116*).

Pumping effect in oil lubricated applications

The internal design of spherical roller thrust bearings creates a pumping action, which produces a flow from the small to the large roller end face, that can be taken advantage of in oil lubricated applications. This pumping action occurs in applications where the shaft is vertical or horizontal (*fig. 6*) and should be considered when selecting the type of lubricant and sealing arrangement.

For bearings with a machined cage used in high-speed applications, SKF recommends the oil injection lubrication method (*fig. 7*).

For additional information about lubricating spherical roller thrust bearings, contact the SKF application engineering service.

Diagram 1

Minimum load requirements for spherical roller thrust bearings

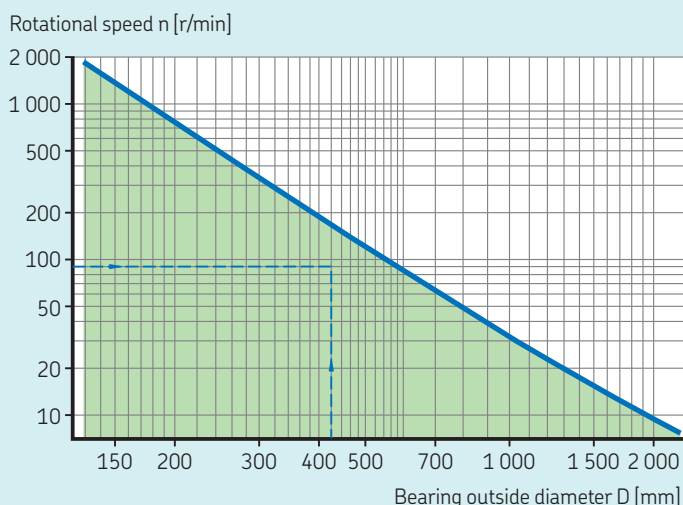
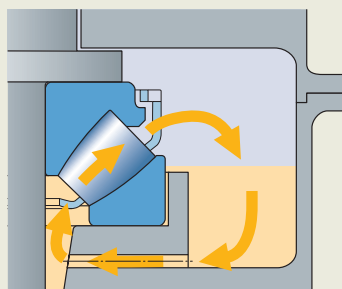

Fig. 6

Fig. 7

Pumping effect



Vertical shaft application

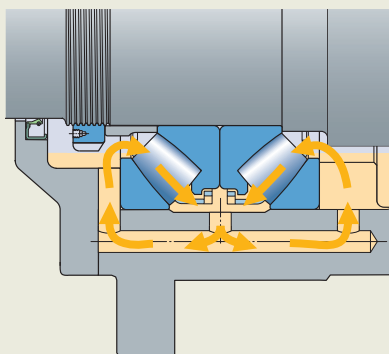

Horizontal shaft application

Oil injection lubrication method

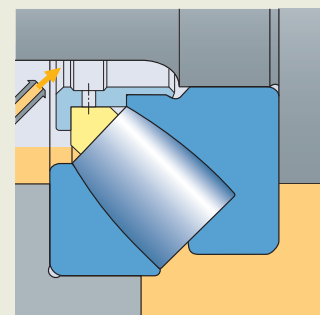

Mounting

SKF spherical roller thrust bearings are separable, making it possible to mount and dismount the housing washer separately from the shaft washer and roller and cage assembly.

Where a spherical roller thrust bearing with a machined metal cage is to be replaced by an E design bearing with a stamped steel window-type cage, and axial forces are transmitted via the cage guiding sleeve, a spacer ring must be inserted between the shaft abutment and the shaft washer (fig. 8).

The spacer ring must be hardened and its side faces should be ground. Appropriate spacer ring dimensions for SKF spherical roller thrust bearings are listed in the [product table, page 922](#).

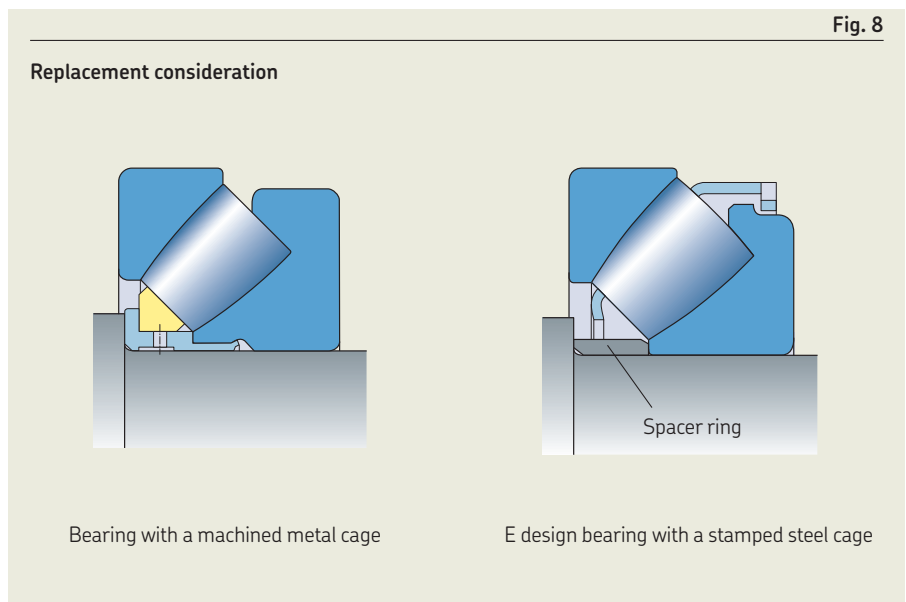

Designation system

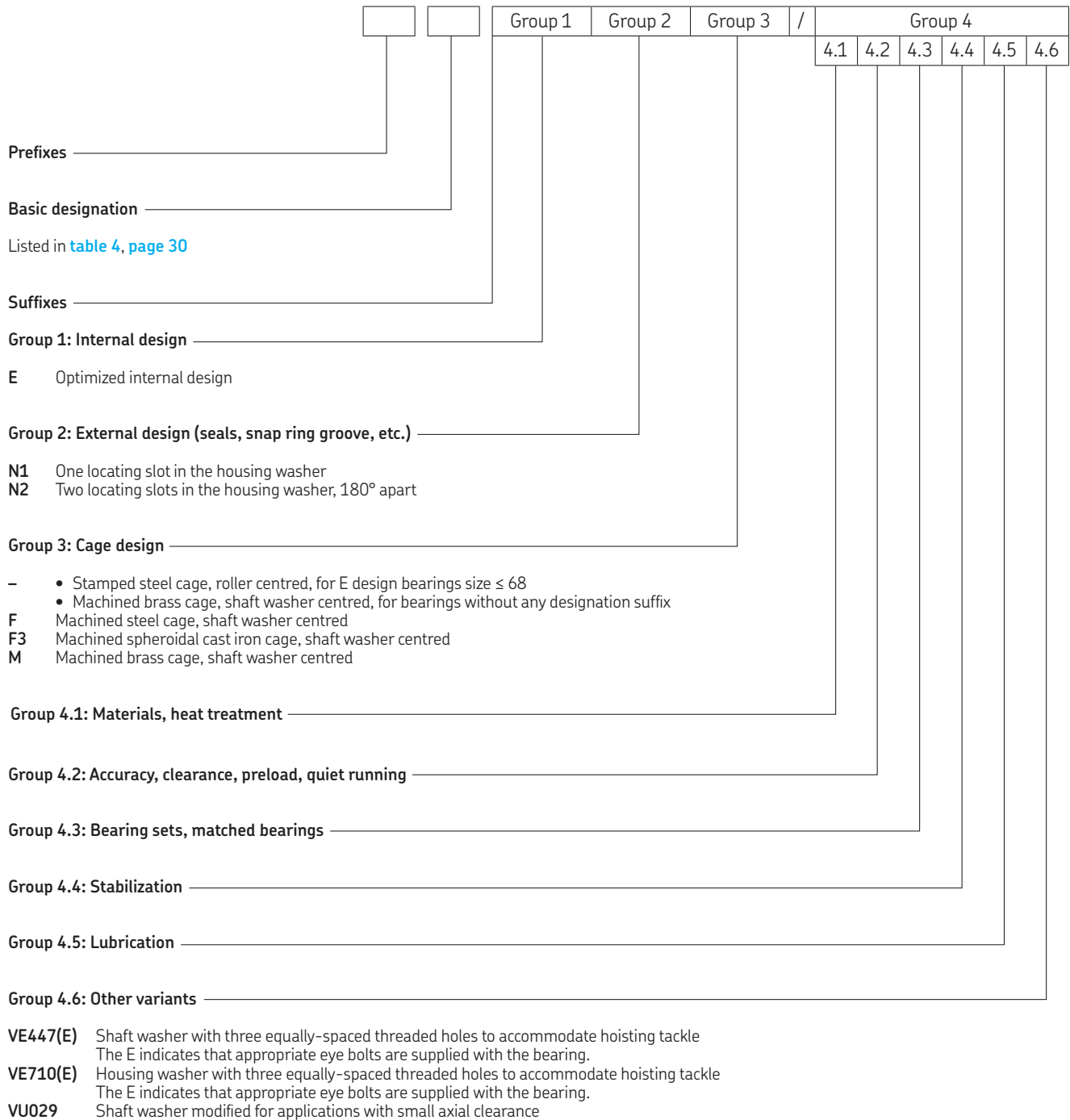

13.1 Spherical roller thrust bearings

d 60 – 180 mm

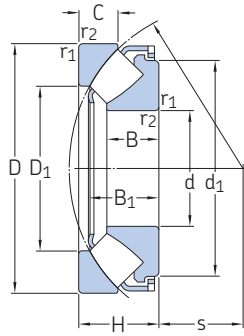

Principal dimensions			Basic load ratings		Fatigue load limit	Minimum load factor	Speed ratings		Mass	Designation
d	D	H	C	C ₀			Reference speed	Limiting speed		
mm			kN		kN	–	r/min	kg	–	
60	130	42	390	915	114	0,08	2 800	5 000	2,6	▶ 29412 E
65	140	45	455	1 080	137	0,11	2 600	4 800	3,2	▶ 29413 E
70	150	48	520	1 250	153	0,15	2 400	4 300	3,9	▶ 29414 E
75	160	51	600	1 430	173	0,19	2 400	4 000	4,7	▶ 29415 E
80	170	54	670	1 630	193	0,25	2 200	3 800	5,6	▶ 29416 E
85	150	39	380	1 060	129	0,11	2 400	4 000	2,75	▶ 29317 E
	180	58	735	1 800	212	0,31	2 000	3 600	6,75	▶ 29417 E
90	155	39	400	1 080	132	0,11	2 400	4 000	2,85	▶ 29318 E
	190	60	815	2 000	232	0,38	1 900	3 400	7,75	▶ 29418 E
100	170	42	465	1 290	156	0,16	2 200	3 600	3,65	▶ 29320 E
	210	67	980	2 500	275	0,59	1 700	3 000	10,5	▶ 29420 E
110	190	48	610	1 730	204	0,28	1 900	3 200	5,3	▶ 29322 E
	230	73	1 180	3 000	325	0,86	1 600	2 800	13,5	▶ 29422 E
120	210	54	765	2 120	245	0,43	1 700	2 800	7,35	▶ 29324 E
	250	78	1 370	3 450	375	1,1	1 500	2 600	17,5	▶ 29424 E
130	225	58	865	2 500	280	0,59	1 600	2 600	9	▶ 29326 E
	270	85	1 560	4 050	430	1,6	1 300	2 400	22	▶ 29426 E
140	240	60	980	2 850	315	0,77	1 500	2 600	10,5	▶ 29328 E
	280	85	1 630	4 300	455	1,8	1 300	2 400	23	▶ 29428 E
150	215	39	408	1 600	180	0,24	1 800	2 800	4,3	▶ 29230 E
	250	60	1 000	2 850	315	0,77	1 500	2 400	11	▶ 29330 E
	300	90	1 860	5 100	520	2,5	1 200	2 200	28	▶ 29430 E
160	270	67	1 180	3 450	375	1,1	1 300	2 200	14,5	▶ 29332 E
	320	95	2 080	5 600	570	3	1 100	2 000	32	▶ 29432 E
170	280	67	1 200	3 550	365	1,2	1 300	2 200	15	▶ 29334 E
	340	103	2 360	6 550	640	4,1	1 100	1 900	44,5	▶ 29434 E
180	250	42	495	2 040	212	0,4	1 600	2 600	5,8	▶ 29236 E
	300	73	1 430	4 300	440	1,8	1 200	2 000	19,5	▶ 29336 E
	360	109	2 600	7 350	710	5,1	1 000	1 800	52,5	▶ 29436 E

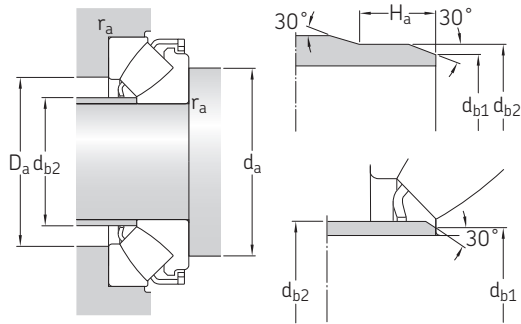

Dimensions								Abutment and fillet dimensions					
d	d ₁ ≈	D ₁ ≈	B	B ₁	C	r _{1,2} min.	s	d _a min.	d _{b1} max.	d _{b2} max.	H _a min.	D _a max.	r _a max.
mm								mm					
60	112	85,5	27	36,7	21	1,5	38	90	67	67	–	107	1,5
65	120	91,5	29,5	39,8	22	2	42	100	72	72	–	117	2
70	129	99	31	41	23,8	2	44,8	105	77	77	–	125	2
75	138	106	33,5	45,7	24,5	2	47	115	82	82	–	133	2
80	147	113	35	48,1	26,5	2,1	50	120	88	88	–	141	2
85	134 155	110 121	24,5 37	33,8 51,1	20 28	1,5 2,1	50 54	115 130	90 94	90 94	– –	129 151	1,5 2
90	138 164	115 128	24,5 39	34,5 54	19,5 28,5	1,5 2,1	53 56	120 135	95 99	95 99	– –	134 158	1,5 2
100	152 182	128 142	26,2 43	36,3 57,3	20,5 32	1,5 3	58 62	130 150	107 110	107 110	– –	147 175	1,5 2,5
110	171 199	140 156	30,3 47	41,7 64,7	24,8 34,7	2 3	63,8 69	145 165	117 120	117 129	– –	164 193	2 2,5
120	188 216	155 171	34 50,5	48,2 70,3	27 36,5	2,1 4	70 74	160 180	128 132	128 142	– –	181 209	2 3
130	203 234	166 185	36,7 54	50,6 76	30,1 40,9	2,1 4	75,6 81	175 195	138 142	143 153	– –	194 227	2 3
140	216 245	177 195	38,5 54	54 75,6	30 41	2,1 4	82 86	185 205	148 153	154 162	– –	208 236	2 3
150	200 223 262	176 190 208	24 38 58	34,3 54,9 80,8	20,5 28 43,4	1,5 2,1 4	82 87 92	180 195 220	154 158 163	154 163 175	14 – –	193 219 253	1,5 2 3
160	243 279	203 224	42 60,5	60 84,3	33 45,5	3 5	92 99	210 235	169 175	176 189	– –	235 270	2,5 4
170	251 297	215 236	42,2 65,5	61,1 91,2	30,5 50	3 5	96 104	220 250	178 185	188 199	– –	245 286	2,5 4
180	234 270 315	208 227 250	26 46 69,5	36,9 66,2 96,4	22 35,5 53	1,5 3 5	97 103 110	210 235 265	187 189 196	187 195 210	14 – –	226 262 304	1,5 2,5 4

13.1 Spherical roller thrust bearings

d 190 – 380 mm

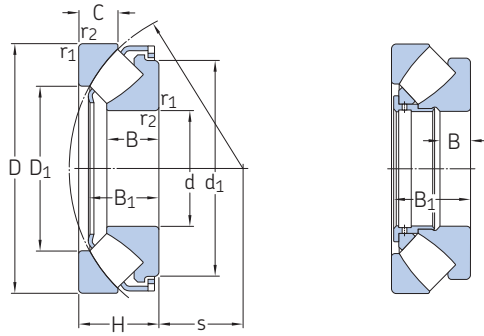

E design

Principal dimensions			Basic load ratings		Fatigue load limit	Minimum load factor	Speed ratings		Mass	Designation
d	D	H	C	C ₀			Reference speed	Limiting speed		
mm			kN		kN	–	r/min	kg	–	
190	320	78	1 630	4 750	490	2,1	1 100	1 900	23,5	▶ 29338 E
	380	115	2 850	8 000	765	6,1	950	1 700	60,5	▶ 29438 E
200	280	48	656	2 650	285	0,67	1 400	2 200	9,3	▶ 29240 E
	340	85	1 860	5 500	550	2,9	1 000	1 700	28,5	▶ 29340 E
	400	122	3 200	9 000	850	7,7	850	1 600	72	▶ 29440 E
220	300	48	690	3 000	310	0,86	1 300	2 200	10	▶ 29244 E
	360	85	2 000	6 300	610	3,8	1 000	1 700	31	▶ 29344 E
	420	122	3 350	9 650	900	8,8	850	1 500	75	▶ 29444 E
240	340	60	799	3 450	335	1,1	1 100	1 800	16,5	▶ 29248
	380	85	2 040	6 550	630	4,1	1 000	1 600	35,5	▶ 29348 E
	440	122	3 400	10 200	930	9,9	850	1 500	80	▶ 29448 E
260	360	60	817	3 650	345	1,3	1 100	1 700	18,5	▶ 29252
	420	95	2 550	8 300	780	6,5	850	1 400	49	▶ 29352 E
	480	132	4 050	12 900	1 080	16	750	1 300	105	▶ 29452 E
280	380	60	863	4 000	375	1,5	1 000	1 700	19,5	▶ 29256
	440	95	2 550	8 650	800	7,1	850	1 400	53	▶ 29356 E
	520	145	4 900	15 300	1 320	22	670	1 200	135	▶ 29456 E
300	420	73	1 070	4 800	465	2,2	900	1 400	30,5	▶ 29260
	480	109	3 100	10 600	930	11	750	1 200	75	▶ 29360 E
	540	145	5 000	16 600	1 340	24	670	1 200	140	▶ 29460 E
320	440	73	1 110	5 100	465	2,5	850	1 400	33	29264
	500	109	3 350	11 200	1 000	12	750	1 200	78	▶ 29364 E
	580	155	5 700	19 000	1 530	32	600	1 100	175	▶ 29464 E
340	460	73	1 130	5 400	480	2,8	850	1 300	33,5	29268
	540	122	2 710	11 000	950	11	600	1 100	105	29368
	620	170	6 700	22 400	1 760	46	560	1 000	220	▶ 29468 E
360	500	85	1 460	6 800	585	4,4	750	1 200	52	29272
	560	122	2 760	11 600	980	13	600	1 100	110	▶ 29372
	640	170	6 200	21 200	1 630	41	560	950	230	▶ 29472 EM
380	520	85	1 580	7 650	655	5,6	700	1 100	53	29276
	600	132	3 340	14 000	1 160	19	530	1 000	140	▶ 29376
	670	175	6 800	24 000	1 860	53	530	900	260	▶ 29476 EM

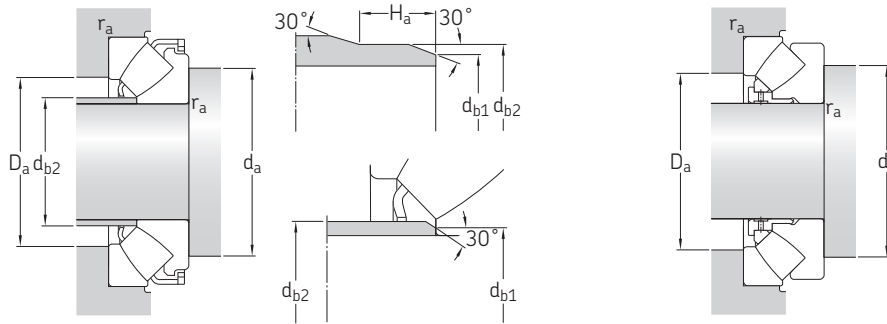

Dimensions

Abutment and fillet dimensions

d	d ₁ ≈	D ₁ ≈	B	B ₁	C	r _{1,2} min.	s	d _a min.	d _{b1} max.	d _{b2} max.	H _a min.	D _a max.	r _a max.
mm								mm					
190	285	244	49	71,3	36	4	110	250	200	211	–	280	3
	332	265	73	101	55,5	5	117	280	207	223	–	321	4
200	260	233	30	43,4	24	2	108	235	206	207	17	253	2
	304	257	53,5	76,7	40	4	116	265	211	224	–	297	3
	350	278	77	107,1	59,4	5	122	295	217	234	–	337	4
220	280	252	30	43,4	24,5	2	117	255	224,5	227	17	271	2
	326	274	55	77,7	41	4	125	285	229	240	–	316	3
	371	300	77	107,4	58,5	6	132	315	238	254	–	358	5
240	330	283	19	57	30	2,1	130	290	–	–	–	308	2
	345	296	54	77,8	40,5	4	135	305	249	259	–	336	3
	391	322	76	107,1	59	6	142	335	258	276	–	378	5
260	350	302	19	57	30	2,1	139	310	–	–	–	326	2
	382	324	61	86,6	46	5	148	335	273	286	–	370	4
	427	346	86	119	63	6	154	365	278	296	–	412	5
280	370	323	19	57	30,5	2,1	150	325	–	–	–	347	2
	401	343	62	86,7	45,5	5	158	355	293	305	–	390	4
	464	372	95	129,9	70	6	166	395	300	320	–	446	5
300	405	353	21	69	38	3	162	360	–	–	–	380	2,5
	434	372	70	98,9	51	5	168	385	313	329	–	423	4
	485	392	95	130,3	70,5	6	175	415	319	340	–	465	5
320	430	372	21	69	38	3	172	380	–	–	–	400	2,5
	454	391	68	97,8	53	5	180	405	332	347	–	442	4
	520	422	102	139,4	74,5	7,5	191	450	344	367	–	500	6
340	445	395	21	69	37,5	3	183	400	–	–	–	422	2,5
	520	428	40,6	117	59,5	5	192	440	–	–	–	479	4
	557	445	112	151,4	84	7,5	201	475	363	386	–	530	6
360	485	423	25	81	44	4	195	430	–	–	–	453	3
	540	448	40,5	117	59,5	5	202	460	–	–	–	500	4
	580	474	63	164	83,5	7,5	210	495	–	–	–	550	6
380	505	441	27	81	42	4	202	450	–	–	–	473	3
	580	477	45	127	63,5	6	216	495	–	–	–	535	5
	610	494	67	168	87,5	7,5	222	525	–	–	–	580	6

13.1 Spherical roller thrust bearings

d 400 – 750 mm

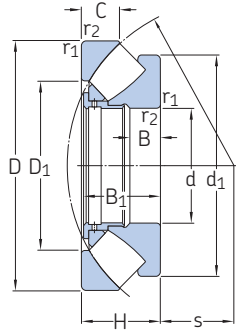

Principal dimensions			Basic load ratings		Fatigue load limit	Minimum load factor	Speed ratings		Mass	Designation
d	D	H	C	C ₀			P _u	A		
mm			kN		kN	–	r/min	kg	–	
400	540	85	1 610	8 000	695	6,1	700	1 100	55,5	29280
	620	132	3 450	14 600	1 200	20	530	950	150	29380
	710	185	7 650	26 500	1 960	62	480	850	310	▶ 29480 EM
420	580	95	1 990	9 800	815	9,1	630	1 000	75,5	29284
	650	140	3 740	16 000	1 290	24	500	900	170	29384
	730	185	7 800	27 500	2 080	69	480	850	325	▶ 29484 EM
440	600	95	2 070	10 400	850	10	630	1 000	78	29288
	680	145	5 200	19 300	1 560	34	530	850	180	29388 EM
	780	206	9 000	32 000	2 320	91	430	750	410	▶ 29488 EM
460	620	95	2 070	10 600	865	11	600	950	81	29292
	710	150	4 310	19 000	1 500	34	450	800	215	29392
	800	206	9 300	33 500	2 450	100	430	750	425	29492 EM
480	650	103	2 350	11 800	950	13	560	900	98	29296
	850	224	9 550	39 000	2 800	140	340	670	550	▶ 29496 EM
500	670	103	2 390	12 500	1 000	15	560	900	100	292/500
	750	150	4 490	20 400	1 560	40	430	800	235	293/500
	870	224	9 370	40 000	2 850	150	340	670	560	▶ 294/500 EM
530	710	109	3 110	15 300	1 220	22	530	850	115	292/530 EM
	800	160	5 870	26 500	2 080	67	400	750	265	293/530 EM
	920	236	10 500	44 000	3 100	180	320	630	650	▶ 294/530 EM
560	750	115	2 990	16 000	1 220	24	480	800	140	292/560
	980	250	12 000	51 000	3 550	250	300	560	810	294/560 EM
600	800	122	3 740	18 600	1 460	33	450	700	170	292/600 EM
	1 030	258	13 100	56 000	4 000	300	280	530	845	294/600 EM
630	850	132	4 770	23 600	1 800	53	400	670	210	292/630 EM
	950	190	8 450	38 000	2 900	140	320	600	485	293/630 EM
	1 090	280	14 400	62 000	4 150	370	260	500	1 040	▶ 294/630 EM
670	1 150	290	15 400	68 000	4 500	440	240	450	1 210	▶ 294/670 EM
710	1 060	212	9 950	45 500	3 400	200	280	500	610	▶ 293/710 EM
	1 220	308	17 600	76 500	5 000	560	220	430	1 500	▶ 294/710 EF
750	1 280	315	18 700	85 000	5 500	690	200	400	1 650	▶ 294/750 EF

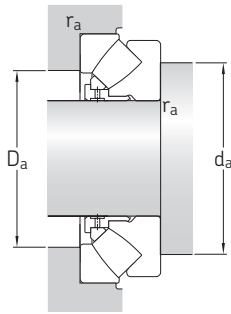

Dimensions								Abutment and fillet dimensions					
d	d ₁ ≈	D ₁ ≈	B	B ₁	C	r _{1,2} min.	s	d _a min.	d _{b1} max.	d _{b2} max.	H _a min.	D _a max.	r _a max.
mm								mm					
400	526	460	27	81	42,2	4	212	470	–	–	–	493	3
	596	494	43	127	64	6	225	510	–	–	–	550	5
	645	525	69	178	89,5	7,5	234	550	–	–	–	615	6
420	564	489	30	91	46	5	225	500	–	–	–	525	4
	626	520	49	135	67,5	6	235	535	–	–	–	580	5
	665	545	70	178	90,5	7,5	244	575	–	–	–	635	6
440	585	508	30	91	46,5	5	235	520	–	–	–	545	4
	626	540	49	140	70,5	6	249	560	–	–	–	605	5
	710	577	77	199	101	9,5	257	605	–	–	–	675	8
460	605	530	30	91	46	5	245	540	–	–	–	565	4
	685	567	50	144	72,5	6	257	585	–	–	–	630	5
	730	596	77	199	101,5	9,5	268	630	–	–	–	695	8
480	635	556	33	99	53,5	5	259	570	–	–	–	595	4
	770	625	88	216	108	9,5	280	660	–	–	–	735	8
500	654	574	33	99	53,5	5	268	585	–	–	–	615	4
	725	611	50	144	74	6	280	630	–	–	–	675	5
	795	648	86	216	110	9,5	290	685	–	–	–	755	8
530	675	608	32	105	56	5	285	620	–	–	–	655	4
	741	641	55	154	81	7,5	295	665	–	–	–	715	6
	840	686	89	228	116	9,5	308	725	–	–	–	800	8
560	732	644	37	111	61	5	302	655	–	–	–	685	4
	890	727	99	241	122	12	328	770	–	–	–	850	10
600	760	688	39	117	60	5	321	700	–	–	–	735	4
	940	769	99	249	128	12	349	815	–	–	–	900	10
630	810	723	50	127	62	6	338	740	–	–	–	780	5
	880	761	68	183	92	9,5	359	795	–	–	–	860	8
	995	815	107	270	137	12	365	860	–	–	–	950	10
670	1 045	864	110	280	141	15	387	905	–	–	–	1 000	12
710	985	855	74	205	103	9,5	404	890	–	–	–	960	8
	1 110	917	117	298	149	15	415	965	–	–	–	1 070	12
750	1 170	964	121	305	153	15	436	1 015	–	–	–	1 120	12

13.1 Spherical roller thrust bearings

d 800 – 1 060 mm

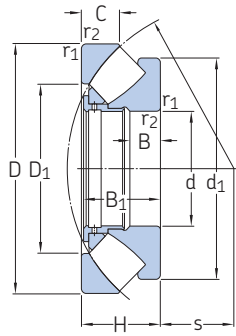

Principal dimensions			Basic load ratings		Fatigue load limit	Minimum load factor	Speed ratings		Mass	Designation
d	D	H	dynamic	static			Reference speed	Limiting speed		
mm			kN		kN	–	r/min	kg	–	
800	1 060	155	6 560	34 500	2 550	110	320	530	380	292/800 EM
	1 180	230	11 300	55 000	3 900	290	240	450	810	293/800 EM
	1 360	335	20 200	93 000	5 850	820	190	360	2 030	▶ 294/800 EF
850	1 440	354	23 900	108 000	7 100	1 100	170	340	2 390	▶ 294/850 EF
900	1 520	372	26 700	122 000	7 200	1 400	160	300	2 650	▶ 294/900 EF
950	1 600	390	28 200	132 000	7 800	1 700	140	280	3 070	294/950 EF
1 000	1 670	402	31 100	140 000	8 650	1 900	130	260	3 390	▶ 294/1000 EF
1 060	1 770	426	33 400	156 000	8 500	2 300	120	240	4 280	294/1060 EF

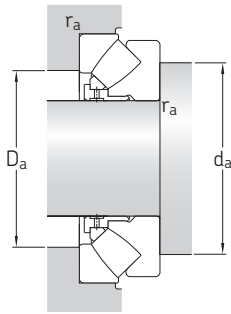

Dimensions								Abutment and fillet dimensions					
d	d_1 ≈	D_1 ≈	B	B_1	C	$r_{1,2}$ min.	s	d_a min.	d_{b1} max.	d_{b2} max.	H_a min.	D_a max.	r_a max.
mm								mm					
800	1 010	911	52	149	77	7,5	434	935	–	–	–	980	6
	1 099	958	78	222	117	9,5	440	985	–	–	–	1 060	8
	1 250	1 034	123	324	165	15	462	1 080	–	–	–	1 185	12
850	1 315	1 077	142	342	172	15	507	1 160	–	–	–	1 270	12
900	1 394	1 137	147	360	186	15	518	1 215	–	–	–	1 320	12
950	1 470	1 209	153	377	191	15	546	1 275	–	–	–	1 400	12
1 000	1 531	1 270	154,9	389	190	15	599	1 350	–	–	–	1 490	12
1 060	1 615	1 349	192	412	207	15	610	1 410	–	–	–	1 555	12