

10

CARB toroidal  
roller bearings

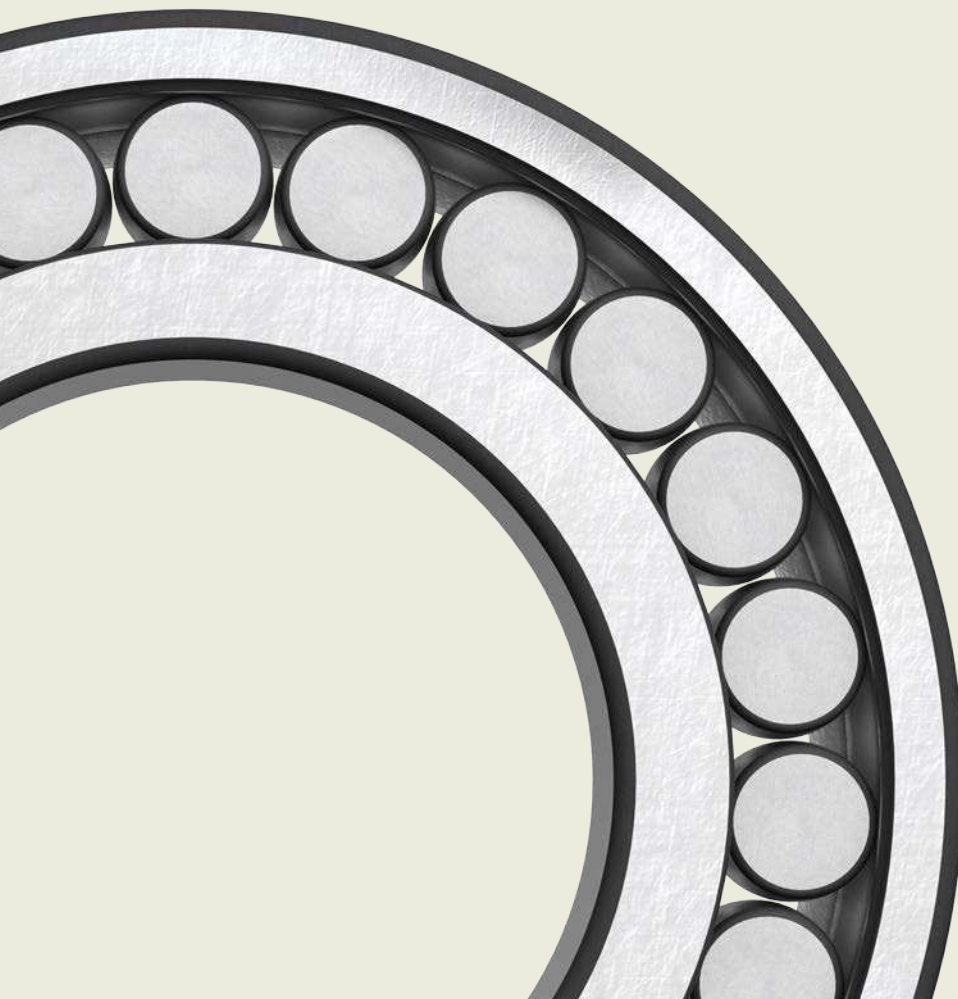

# 10 CARB toroidal roller bearings

<b>Designs and variants</b> .....	<b>844</b>		
Basic design bearings .....	844		
Sealed bearings .....	845		
Cages .....	845		
Customized bearings .....	845		
<b>Bearing data</b> .....	<b>846</b>		
(Dimension standards, tolerances, internal clearance, permissible misalignment, permissible axial displacement)			
<b>Loads</b> .....	<b>849</b>		
(Minimum load, equivalent dynamic bearing load, equivalent static bearing load)			
<b>Temperature limits</b> .....	<b>850</b>		
<b>Permissible speed</b> .....	<b>850</b>		
<b>Design considerations</b> .....	<b>850</b>		
Verification of axial displacement .....	850		
Free space on both sides of the bearing .....	852		
Offset mounting .....	852		
Bearings on sleeves .....	852		
Appropriate bearing housings .....	852		
<b>Mounting</b> .....	<b>853</b>		
Mounting bearings with a tapered bore .....	853		
<b>Designation system</b> .....	<b>855</b>		
<b>Product tables</b>			
<b>10.1</b> CARB toroidal roller bearings .....	856		
<b>10.2</b> CARB toroidal roller bearings on an adapter sleeve .....	868		
<b>10.3</b> CARB toroidal roller bearings on a withdrawal sleeve .....	872		
		<b>Other CARB toroidal roller bearings</b>	
		NoWear coated bearings .....	1059



# 10 CARB toroidal roller bearings

## More information

General bearing knowledge . . . .	17
<b>Bearing selection process . . . . .</b>	<b>59</b>
Lubrication . . . . .	109
Bearing interfaces . . . . .	139
Seat tolerances for standard conditions . . . . .	148
Selecting internal clearance . . . . .	182
Sealing, mounting and dismounting . . . . .	193

**Mounting instructions for individual bearings** → [skf.com/mount](https://skf.com/mount)

**SKF Drive-up Method** → [skf.com/drive-up](https://skf.com/drive-up)

*SKF bearing maintenance handbook* ISBN 978-91-978966-4-1



Fig. 1

CARB toroidal roller bearing

CARB toroidal roller bearings (fig. 1) have one row of long, slightly barrel-shaped symmetrical rollers and torus-shaped raceway profiles (fig. 2). They are non-locating bearings and accommodate exclusively radial loads. CARB bearings are often used to replace the non-locating spherical roller bearing in a locating/non-locating bearing arrangement.

### Bearing features

- **Accommodate misalignment**  
CARB bearings are self-aligning like spherical roller bearings or self-aligning ball bearings (fig. 3).
- **Accommodate axial displacement**  
CARB bearings compensate for thermal expansion of the shaft like cylindrical or needle roller bearings (fig. 4).

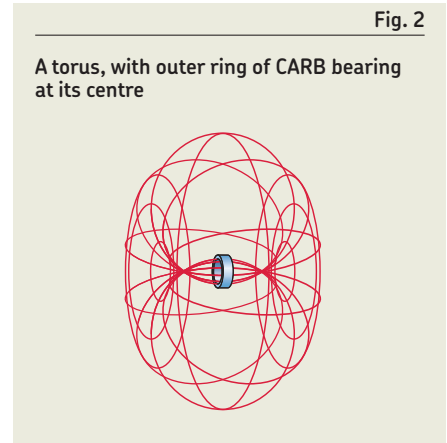

Fig. 2

A torus, with outer ring of CARB bearing at its centre

- **Wide assortment of dimension series**  
CARB bearings are available with the same boundary dimensions as corresponding spherical roller bearings, self-aligning ball bearings, cylindrical roller bearings and needle roller bearings (fig. 5).
- **Long service life**  
The special roller profile prevents stress peaks at the roller ends (fig. 6).
- **Low friction**  
Self-guiding rollers keep friction and frictional heat at low levels (fig. 7).
- **Improved wear resistance**  
All CARB bearings are upgraded SKF Explorer bearings (page 7).
- **Low noise**  
CARB bearings can reduce noise and vibration levels, for example, in paper machines and fans.

Fig. 3

Misalignment

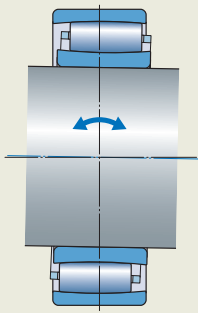

Fig. 5

Interchangeability

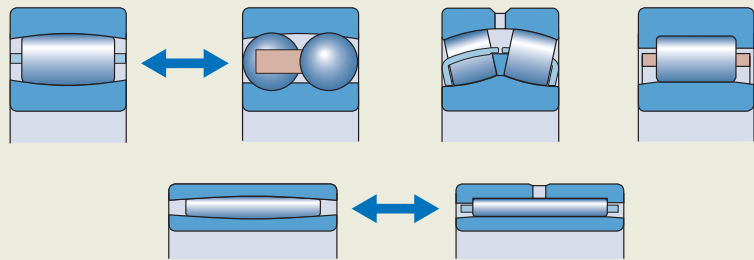

Fig. 4

Axial displacement

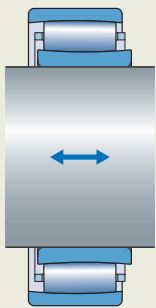

Fig. 6

Optimal stress distribution

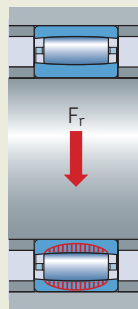
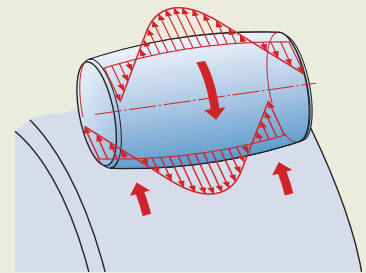

Fig. 7

Low friction and frictional heat



Long bearing system life

CARB bearings provide benefits in self-aligning bearing arrangements (fig. 8). With a CARB bearing in the non-locating position, there are no internally induced axial forces, which results in multiple benefits:

- Less load extends the service life.
- The bearings run cooler, the lubricant lasts longer and maintenance intervals can be extended.
- Noise and vibration levels can be reduced.

Learn more about the SKF self-aligning bearing arrangement in the video available at [skf.com/go/17000-10](http://skf.com/go/17000-10) (4 min).

Fig. 8

Self-aligning bearing arrangement: Locating spherical roller bearing and non-locating CARB bearing

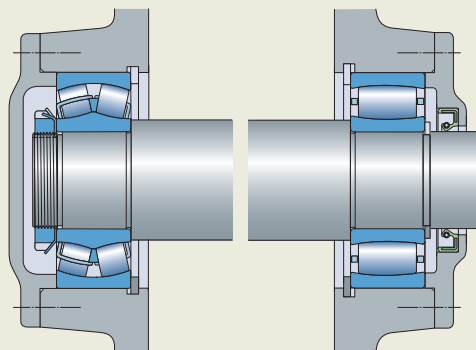

# Designs and variants

## SKF standard assortment

The SKF standard assortment of CARB toroidal roller bearings matches the assortment of spherical roller bearings. It also includes bearings with a low cross-sectional height to meet requirements for minimum radial space. All CARB bearings are upgraded SKF Explorer bearings and are shown coloured blue in the product tables. The standard assortment includes:

- basic design bearings with cylindrical or tapered bore
  - taper 1:12 (designation suffix K)
  - taper 1:30 (designation suffix K30)
- sealed bearings

For sizes and variants not listed in the product tables, contact SKF.

## Basic design bearings

Depending on their series and size the following basic design CARB toroidal roller bearings are available as standard (fig. 9):

- bearings with a roller centred cage
- bearings with an inner ring centred cage
- full complement bearings with a retaining ring

The load carrying capacity of full complement CARB bearings is considerably higher than that of same-sized bearings with a cage.

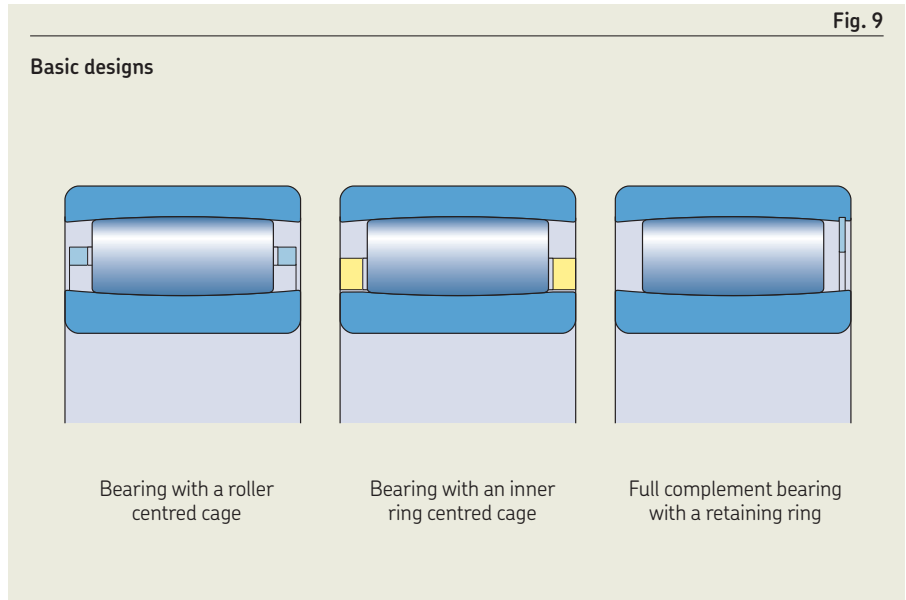

Fig. 9

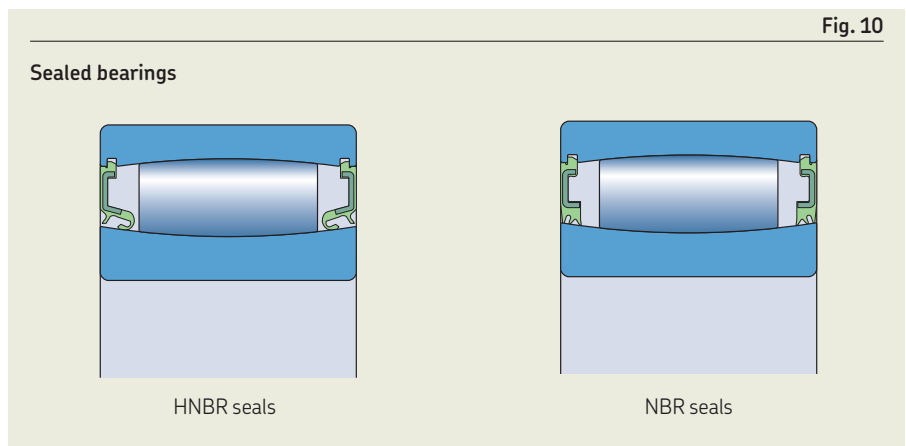

Fig. 10

## Sealed bearings

- are available, as standard, as small and medium-size full complement bearings with a cylindrical bore
- are typically used for low speeds and very heavy loads
- are suitable for both inner or outer ring rotation
- are fitted with a double-lip contact seal on one or both sides in a recess on the outer ring, sealing against the inner ring raceway
- are available with two different seal materials / designs (fig. 10):
  - sheet steel reinforced HNBR (designation suffix CS5)
  - sheet steel reinforced NBR (designation suffix NS) with enhanced sealing effectiveness – mainly intended for oscillating or very low speed applications

Bearings sealed on both sides are lubricated for the life of the bearing and are virtually maintenance-free. They are filled with one of the following greases (table 1):

- bearings with HNBR seals → SKF LGHB 2 grease as standard
- bearings with NBR seals → SKF LGEP 2 grease as standard
- other SKF greases on request

For additional information about greases, refer to *Selecting a suitable SKF grease*, page 116.

## Cages

CARB bearings, if not a full complement of rollers, are fitted with one of the following cages:

- glass fibre reinforced PA46 cage, window-type, roller centred (designation suffix TN9)
- stamped steel cage, window-type, roller centred (no designation suffix)
- machined brass cage, window-type, roller centred (designation suffix M)
- machined brass cage, inner ring centred (designation suffix MB)

When used at high temperatures, some lubricants can have a detrimental effect on polyamide cages. For additional information about the suitability of cages, refer to *Cages*, page 187.

## Customized bearings

SKF can customize bearings to meet the needs of applications where the bearings are subjected to unique operating conditions. For example, bearings for:

- paper mills or coaters in high precision execution
- very arduous operating conditions, e.g. continuous casters
- high temperature applications

For additional information about application-specific CARB bearings, contact the SKF application engineering service.

Table 1

Technical specifications of SKF greases for sealed CARB bearings

Grease	Designation suffix	Temperature range <sup>1)</sup>							Thickener	Base oil type	NLGI grade	Base oil viscosity [mm <sup>2</sup> /s]	
		-50	0	50	100	150	200	250				at 40 °C (105 °F)	at 100 °C (210 °F)
LGEP 2	VT143								Lithium soap	Mineral	2	200	16
LGHB 2	GEM9								Calcium sulphonate complex	Mineral	2	400	26,5

<sup>1)</sup> Refer to the SKF traffic light concept (page 117).

# Bearing data

<b>Dimension standards</b>	Boundary dimensions: ISO 15
<b>Tolerances</b>	Normal  <b>d ≤ 300 mm</b> <ul style="list-style-type: none"> <li>width tolerance at least 50% tighter than ISO standard (<a href="#">table 2</a>)</li> <li>P5 geometrical tolerances</li> </ul> <b>d &gt; 300 mm</b> <ul style="list-style-type: none"> <li>P5 geometrical tolerances on request (designation suffix C08)</li> </ul>
For additional information → <a href="#">page 35</a>	Values: ISO 492 ( <a href="#">table 2, page 38</a> , to <a href="#">table 4, page 40</a> )
<b>Internal clearance</b>	Normal Check availability of C2, C3, C4 or C5 clearance classes  Values: ISO 5753-1 <ul style="list-style-type: none"> <li>cylindrical bore (<a href="#">table 3</a>)</li> <li>tapered bore (<a href="#">table 4, page 848</a>)</li> </ul>
For additional information → <a href="#">page 182</a>	Values are valid for unmounted bearings under zero measuring load, with no misalignment, no axial displacement between the inner and outer rings, and the rollers centred.  Axial displacement of one bearing ring relative to the other reduces the radial internal clearance. Typical clearance window → <a href="#">diagram 1, page 850</a> .
<b>Permissible misalignment</b>	0,5° For misalignment > 0,5°, contact the SKF application engineering service.
<b>Permissible axial displacement</b> ( <a href="#">fig. 11, page 850</a> )	$s_{1\max}, s_{2\max}$ ( <a href="#">product table, page 856</a> )  The actual internal clearance can limit the possible axial displacement. Misalignment reduces the possible axial displacement. For details, refer to <i>Verification of axial displacement</i> , <a href="#">page 850</a> . Free space must be provided on both sides of the bearing ( <i>Free space on both sides of the bearing</i> , <a href="#">page 852</a> ).

Table 2

Width tolerances for CARB bearings

Bore diameter		Width tolerances	
d		$t_{\Delta Bs}$	L
>	≤	U	L
mm		µm	
18	50	0	-40
50	80	0	-60
80	250	0	-80
250	300	0	-100

Table 3

Radial internal clearance of CARB bearings with a cylindrical bore

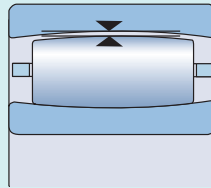

Bore diameter		Radial internal clearance									
d		C2		Normal		C3		C4		C5	
>	≤	min.	max.	min.	max.	min.	max.	min.	max.	min.	max.
mm		μm									
<b>18</b>	<b>24</b>	15	30	25	40	35	55	50	65	65	85
<b>24</b>	<b>30</b>	15	35	30	50	45	60	60	80	75	95
<b>30</b>	<b>40</b>	20	40	35	55	55	75	70	95	90	120
<b>40</b>	<b>50</b>	25	45	45	65	65	85	85	110	105	140
<b>50</b>	<b>65</b>	30	55	50	80	75	105	100	140	135	175
<b>65</b>	<b>80</b>	40	70	65	100	95	125	120	165	160	210
<b>80</b>	<b>100</b>	50	85	80	120	120	160	155	210	205	260
<b>100</b>	<b>120</b>	60	100	100	145	140	190	185	245	240	310
<b>120</b>	<b>140</b>	75	120	115	170	165	215	215	280	280	350
<b>140</b>	<b>160</b>	85	140	135	195	195	250	250	325	320	400
<b>160</b>	<b>180</b>	95	155	150	220	215	280	280	365	360	450
<b>180</b>	<b>200</b>	105	175	170	240	235	310	305	395	390	495
<b>200</b>	<b>225</b>	115	190	185	265	260	340	335	435	430	545
<b>225</b>	<b>250</b>	125	205	200	285	280	370	365	480	475	605
<b>250</b>	<b>280</b>	135	225	220	310	305	410	405	520	515	655
<b>280</b>	<b>315</b>	150	240	235	330	330	435	430	570	570	715
<b>315</b>	<b>355</b>	160	260	255	360	360	485	480	620	620	790
<b>355</b>	<b>400</b>	175	280	280	395	395	530	525	675	675	850
<b>400</b>	<b>450</b>	190	310	305	435	435	580	575	745	745	930
<b>450</b>	<b>500</b>	205	335	335	475	475	635	630	815	810	1 015
<b>500</b>	<b>560</b>	220	360	360	520	510	690	680	890	890	1 110
<b>560</b>	<b>630</b>	240	400	390	570	560	760	750	980	970	1 220
<b>630</b>	<b>710</b>	260	440	430	620	610	840	830	1 080	1 070	1 340
<b>710</b>	<b>800</b>	300	500	490	680	680	920	920	1 200	1 200	1 480
<b>800</b>	<b>900</b>	320	540	530	760	750	1 020	1 010	1 330	1 320	1 660
<b>900</b>	<b>1 000</b>	370	600	590	830	830	1 120	1 120	1 460	1 460	1 830
<b>1 000</b>	<b>1 120</b>	410	660	660	930	930	1 260	1 260	1 640	1 640	2 040
<b>1 120</b>	<b>1 250</b>	450	720	720	1 020	1 020	1 380	1 380	1 800	1 800	2 240
<b>1 250</b>	<b>1 400</b>	490	800	800	1 130	1 130	1 510	1 510	1 970	1 970	2 460
<b>1 400</b>	<b>1 600</b>	570	890	890	1 250	1 250	1 680	1 680	2 200	2 200	2 740
<b>1 600</b>	<b>1 800</b>	650	1 010	1 010	1 390	1 390	1 870	1 870	2 430	2 430	3 000





Radial internal clearance of CARB bearings with a tapered bore

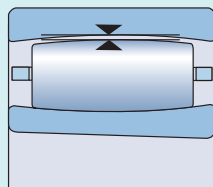

Bore diameter		Radial internal clearance									
d		C2		Normal		C3		C4		C5	
>	≤	min.	max.	min.	max.	min.	max.	min.	max.	min.	max.
mm		µm									
18	24	15	35	30	45	40	55	55	70	65	85
24	30	20	40	35	55	50	65	65	85	80	100
30	40	25	50	45	65	60	80	80	100	100	125
40	50	30	55	50	75	70	95	90	120	115	145
50	65	40	65	60	90	85	115	110	150	145	185
65	80	50	80	75	110	105	140	135	180	175	220
80	100	60	100	95	135	130	175	170	220	215	275
100	120	75	115	115	155	155	205	200	255	255	325
120	140	90	135	135	180	180	235	230	295	290	365
140	160	100	155	155	215	210	270	265	340	335	415
160	180	115	175	170	240	235	305	300	385	380	470
180	200	130	195	190	260	260	330	325	420	415	520
200	225	140	215	210	290	285	365	360	460	460	575
225	250	160	235	235	315	315	405	400	515	510	635
250	280	170	260	255	345	340	445	440	560	555	695
280	315	195	285	280	380	375	485	480	620	615	765
315	355	220	320	315	420	415	545	540	680	675	850
355	400	250	350	350	475	470	600	595	755	755	920
400	450	280	385	380	525	525	655	650	835	835	1 005
450	500	305	435	435	575	575	735	730	915	910	1 115
500	560	330	480	470	640	630	810	800	1 010	1 000	1 230
560	630	380	530	530	710	700	890	880	1 110	1 110	1 350
630	710	420	590	590	780	770	990	980	1 230	1 230	1 490
710	800	480	680	670	860	860	1 100	1 100	1 380	1 380	1 660
800	900	520	740	730	960	950	1 220	1 210	1 530	1 520	1 860
900	1 000	580	820	810	1 040	1 040	1 340	1 340	1 670	1 670	2 050
1 000	1 120	640	900	890	1 170	1 160	1 500	1 490	1 880	1 870	2 280
1 120	1 250	700	980	970	1 280	1 270	1 640	1 630	2 060	2 050	2 500
1 250	1 400	770	1 080	1 080	1 410	1 410	1 790	1 780	2 250	2 250	2 740
1 400	1 600	870	1 200	1 200	1 550	1 550	1 990	1 990	2 500	2 500	3 050
1 600	1 800	950	1 320	1 320	1 690	1 690	2 180	2 180	2 730	2 730	3 310

# Loads

	Bearings with a cage	Full complement bearings
<p><b>Minimum load</b></p> <p>For additional information → <a href="#">page 106</a></p>	$F_{rm} = 0,007 C_0$  <p><b>Oil lubricated bearings:</b></p> $n/n_r \leq 0,3 \rightarrow F_{rm} = 0,002 C_0$  $0,3 < n/n_r \leq 2 \rightarrow F_{rm} = 0,002 C_0 (1 + 2 \sqrt{\frac{n}{n_r} - 0,3})$  When starting up at low temperatures or when the lubricant is highly viscous, greater minimum loads than $F_{rm} = 0,007 C_0$ and $0,01 C_0$ , respectively, may be required.	$F_{rm} = 0,01 C_0$
<p><b>Equivalent dynamic bearing load</b></p> <p>For additional information → <a href="#">page 91</a></p>	$P = F_r$	
<p><b>Equivalent static bearing load</b></p> <p>For additional information → <a href="#">page 105</a></p>	$P_0 = F_r$	
	<p><b>Symbols</b></p> <p><math>C_0</math> basic static load rating [kN] (<a href="#">product table, page 856</a>)</p> <p><math>F_r</math> radial load [kN]</p> <p><math>F_{rm}</math> minimum radial load [kN]</p> <p><math>P</math> equivalent dynamic bearing load [kN]</p> <p><math>P_0</math> equivalent static bearing load [kN]</p> <p><math>n</math> rotational speed [r/min]</p> <p><math>n_r</math> reference speed [r/min] (<a href="#">product table</a>)</p>	

# Temperature limits

The permissible operating temperature for CARB bearings can be limited by:

- the dimensional stability of the bearing rings
- the cage
- the seals
- the lubricant

Where temperatures outside the permissible range are expected, contact SKF.

## Bearing rings

The rings of CARB bearings are heat stabilized up to 200 °C (390 °F).

## Cages

Steel or brass cages can be used at the same operating temperatures as the bearing rings. For temperature limits of polymer cages, refer to *Polymer cages*, page 188.

## Seals

The permissible operating temperature for seals depends on the seal material:

- HNBR: -40 to +150 °C (-40 to +300 °F)
  - NBR: -40 to +90 °C (-40 to +195 °F)
- Temperatures up to 120 °C (250 °F) can be tolerated for brief periods.

Typically, temperature peaks are at the seal lip.

## Lubricants

Temperature limits for greases used in sealed CARB bearings are provided in [table 1, page 845](#). For temperature limits of other SKF greases, refer to *Selecting a suitable SKF grease*, page 116.

When using lubricants not supplied by SKF, temperature limits should be evaluated according to the SKF traffic light concept ([page 117](#)).

# Permissible speed

The speed ratings in the [product table](#) indicate:

- the **reference speed**, which enables a quick assessment of the speed capabilities from a thermal frame of reference
- the **limiting speed**, which is a mechanical limit that should not be exceeded unless the bearing design and the application are adapted for higher speeds

For additional information, refer to *Operating temperature and speed*, [page 130](#).

# Design considerations

## Verification of axial displacement

The actual internal clearance can limit the possible axial displacement. Misalignment reduces the possible axial displacement. Therefore, the actual axial displacement should be verified.

### 1 Determine the required axial displacement

- Thermal expansion of the shaft can be estimated using  $s_{req} = \alpha L \Delta T$
- Where additional effects need to be considered, advanced simulation or tests may be required.

Fig. 11

### Permissible axial displacement

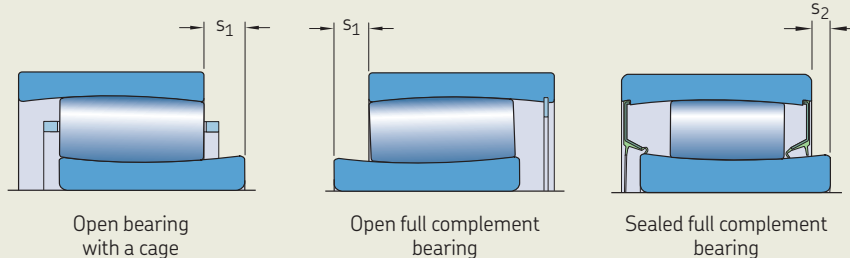
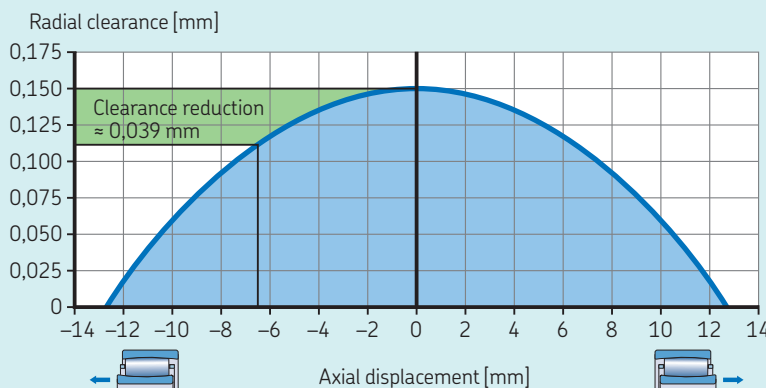

Diagram 1

The clearance window for a C 3052 CARB bearing with a maximum operating clearance of 0,150 mm



## 2 Determine the maximum misalignment

- Estimate the misalignment  $\beta$  of the housing seats based on specified tolerances.
- Where additional effects need to be considered, advanced simulation or tests may be required.

## 3 Check the permissible axial displacement

Check the permissible axial displacement in both directions, depending on the bearing used (fig. 11):

- open bearing with a cage
- full complement bearing with a retaining ring
- sealed bearing

$$s_{\text{req}} < s_1 - \beta k_1 B$$

or

$$s_{\text{req}} < s_2 - \beta k_1 B$$

Where  $s_{\text{req}}$  is too large, consider *Offset mounting*, page 852.

## 4 Check the internal clearance

- Determine the clearance reduction caused by axial displacement.

$$C_{\text{red}} = \frac{k_2 s_{\text{req}}^2}{B}$$

- Determine the amount of clearance reduction from other effects and evaluate the residual clearance (*Selecting initial internal clearance*, page 183).

### Example application

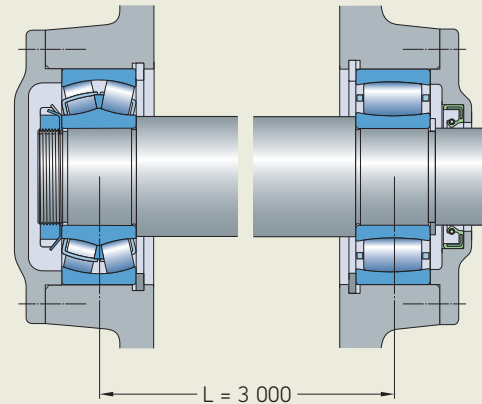

Fig. 12

### Symbols

B	bearing width [mm]
$C_{\text{red}}$	reduction of radial clearance as a result of an axial displacement from a centred position [mm]
$k_1$	misalignment factor (product table, page 856)
L	shaft length between the bearings [mm]
$s_1$	axial displacement limit in bearings with a cage or in full complement bearings when displacing away from the retaining ring [mm] (fig. 11)
$s_2$	axial displacement limit in sealed and full complement bearings when displacing toward the seal or retaining ring respectively [mm] (fig. 11)
$s_{\text{req}}$	required axial displacement from a centred position [mm]
$\alpha$	thermal coefficient of expansion [ $^{\circ}\text{C}^{-1}$ ] = $12 \times 10^{-6}$ for steel
$\beta$	misalignment [ $^{\circ}$ ]
$\Delta T$	temperature difference [ $^{\circ}\text{C}$ ]

### Calculation example

Application (fig. 12)

- Bearing C 3040
  - d = 200 mm
  - D = 310 mm
  - B = 82 mm
  - Normal clearance: min. 170  $\mu\text{m}$
  - $s_1 = 15,2$  mm
  - $k_1 = 0,123$
  - $k_2 = 0,095$
- Shaft length L = 3 000 mm
- Temperature range for the shaft: 20 to 90  $^{\circ}\text{C}$  (70 to 195  $^{\circ}\text{F}$ )
- Max. misalignment: 0,46 $^{\circ}$

Verification of axial displacement:

#### 1 Required axial displacement

$$s_{\text{req}} = \alpha L \Delta T$$

$$s_{\text{req}} = 12 \times 10^{-6} \times 3\,000 \times (90 - 20) = 2,5 \text{ mm}$$

#### 2 Max. misalignment

Input provided: 0,46 $^{\circ}$

#### 3 Checking the permissible axial displacement

$$s_{\text{req}} < s_1 - \beta k_1 B$$

$$2,5 < 15,2 - 0,46 \times 0,123 \times 82 \approx 10,5$$

→ okay

#### 4 Checking the internal clearance

$$C_{\text{red}} = \frac{k_2 s_{\text{req}}^2}{B}$$

$$C_{\text{red}} = \frac{0,095 \times 2,5^2}{82} \approx 0,007$$

Min. internal clearance when the bearing is displaced:

$$170 - 7 = 163 \mu\text{m}$$

Determine the clearance reduction caused by other effects (e.g. interference fit, temperature difference between inner and outer rings) and evaluate the residual clearance (*Selecting initial internal clearance*, page 183)

## Free space on both sides of the bearing

To enable axial displacement of the shaft relative to the housing, free space must be provided on both sides of the bearing as indicated in **fig. 13**. The value for the width of this free space is based on:

- the value  $C_a$  (**product table, page 856**)
- the expected axial displacement of the bearing rings from the central position during operation
- the displacement of the rings caused by misalignment

### Calculating the free space required on both sides of the bearing

$$C_{areq} = C_a + 0,5 (s + \beta k_1 B)$$

where

- $B$  = bearing width [mm]
- $C_a$  = minimum width of space required on both sides of the bearing [mm] (**product table**)
- $C_{areq}$  = width of space required on both sides of the bearing [mm]
- $k_1$  = misalignment factor (**product table**)
- $s$  = relative axial displacement of rings, e.g. thermal shaft expansion [mm]
- $\beta$  = misalignment [°]

## Offset mounting

Where considerable thermal changes in shaft length are a possibility, the inner ring can be mounted offset, relative to the outer ring, up to the axial displacement limit  $s_1$  or  $s_2$  (**fig. 11, page 850**) in the direction opposite to the expected axial displacement (**fig. 14**). The extended permissible axial displacement is used, for example, in the self-aligning bearing arrangements of drying cylinders in paper machines.

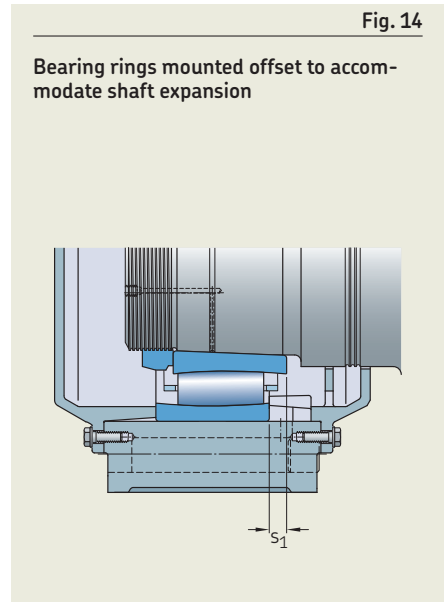
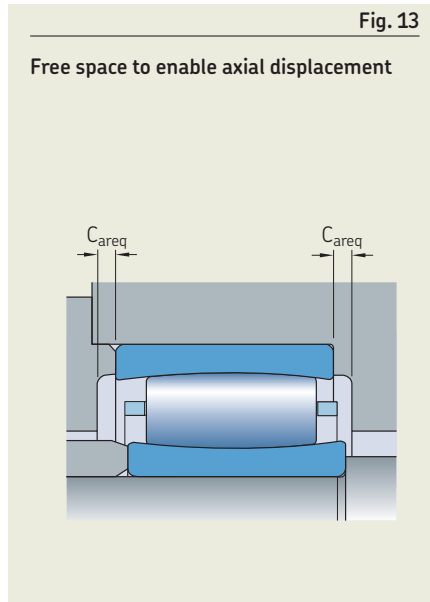

## Bearings on sleeves

CARB bearings with a tapered bore can be mounted with:

- an adapter sleeve on plain or stepped shafts (**fig. 15**):
  - Adapter sleeves are supplied complete with a locking device.
  - Use appropriate SKF adapter sleeve assemblies to prevent the locking device from interfering with the cage (**product table, page 868**).
- a withdrawal sleeve on stepped shafts (**fig. 16**)

Check axial displacement carefully, as it could be that  $s_1$  (**product table, page 856**) cannot be fully realized.

For additional information about sleeves, refer to *Adapter sleeves*, **page 1065**, and *Withdrawal sleeves*, **page 1087**.

## Appropriate bearing housings

SKF standard bearing housings are available for most CARB bearings in the C 30, C 31, C 22 and C 23 series.

The two common arrangements when using standard housings are:

- CARB bearings with a tapered bore on an adapter sleeve and a plain shaft
- CARB bearings with a cylindrical bore on a stepped shaft

The comprehensive assortment of SKF bearing housings is provided online at [skf.com/housings](http://skf.com/housings).

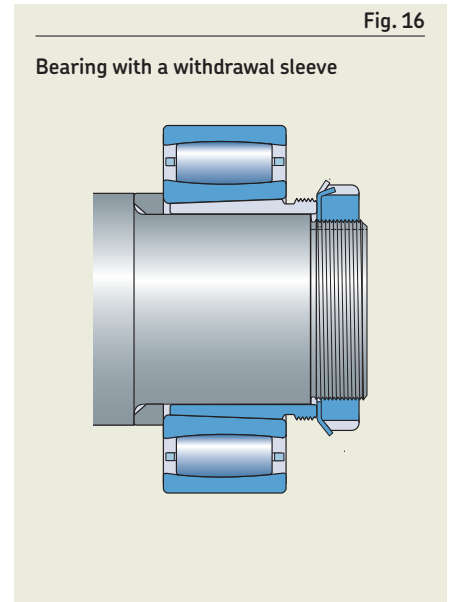
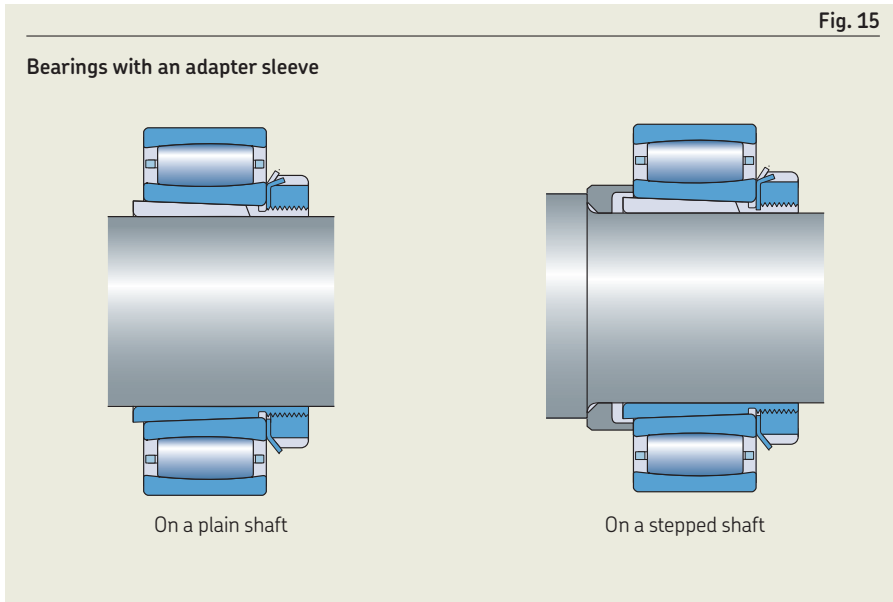

## Mounting

During handling, the rings and roller complement of CARB toroidal roller bearings may be axially displaced from their normal position. This is especially likely where CARB bearings are mounted with the shaft or housing in the vertical position:

- 1 The roller complement, together with the inner or outer ring, will move downward and result in no more clearance.
- 2 When the bearing rings expand or contract as a result of an interference fit, preload is likely to result.

Therefore, wherever possible:

- Mount CARB bearings with the shaft or housing in the horizontal position.
- Rotate the inner or outer ring to align the rollers during mounting.

Where this is not feasible, use a bearing handling tool or other device to keep the bearing components arranged centrally.

## Mounting bearings with a tapered bore

Bearings with a tapered bore are mounted with an interference fit, by using one of the following methods:

- 1 **Measuring the clearance reduction** ([table 5, page 854](#))
- 2 **Measuring the lock nut tightening angle** ([table 5](#))
- 3 **Measuring the axial drive-up** ([table 5](#))
- 4 **Applying the SKF Drive-up Method**  
For bearings with  $d > 100$  mm, SKF recommends using the SKF Drive-up Method. This is a fast, reliable and safe method to achieve the appropriate interference fit. Additional information is available online at [skf.com/drive-up](http://skf.com/drive-up).
- 5 **Measuring the inner ring expansion**  
Additional information is available online at [skf.com/sensormount](http://skf.com/sensormount).

For additional information about these mounting methods, refer to *Mounting bearings with a tapered bore*, [page 203](#), or the *SKF bearing maintenance handbook*.

Drive-up data for CARB bearings with a tapered bore

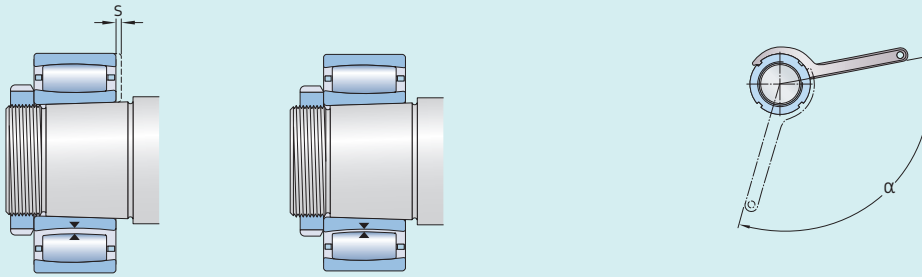

Bore diameter		Reduction of radial internal clearance		Axial drive-up <sup>1)2)</sup>				Lock nut tightening angle <sup>2)</sup>
d				s			α	
>	≤	min.	max.	Taper 1:12	Taper 1:30		Taper 1:12	
mm	mm	mm	mm	min.	max.	min.	max.	°
24	30	0,01	0,015	0,25	0,29	–	–	100
30	40	0,015	0,02	0,3	0,35	0,75	0,9	115
40	50	0,02	0,025	0,37	0,44	0,95	1,1	130
50	65	0,025	0,035	0,45	0,54	1,15	1,35	115
65	80	0,035	0,04	0,55	0,65	1,4	1,65	130
80	100	0,04	0,05	0,66	0,79	1,65	2	150
100	120	0,05	0,06	0,79	0,95	2	2,35	
120	140	0,06	0,075	0,93	1,1	2,3	2,8	
140	160	0,07	0,085	1,05	1,3	2,65	3,2	
160	180	0,08	0,095	1,2	1,45	3	3,6	
180	200	0,09	0,105	1,3	1,6	3,3	4	
200	225	0,1	0,12	1,45	1,8	3,7	4,45	
225	250	0,11	0,13	1,6	1,95	4	4,85	
250	280	0,12	0,15	1,8	2,15	4,5	5,4	
280	315	0,135	0,165	2	2,4	4,95	6	
315	355	0,15	0,18	2,15	2,65	5,4	6,6	
355	400	0,17	0,21	2,5	3	6,2	7,6	
400	450	0,195	0,235	2,8	3,4	7	8,5	
450	500	0,215	0,265	3,1	3,8	7,8	9,5	
500	560	0,245	0,3	3,4	4,1	8,4	10,3	
560	630	0,275	0,34	3,8	4,65	9,5	11,6	
630	710	0,31	0,38	4,25	5,2	10,6	13	
710	800	0,35	0,425	4,75	5,8	11,9	14,5	
800	900	0,395	0,48	5,4	6,6	13,5	16,4	
900	1 000	0,44	0,535	6	7,3	15	18,3	
1 000	1 120	0,49	0,6	6,4	7,8	16	19,5	
1 120	1 250	0,55	0,67	7,1	8,7	17,8	21,7	
1 250	1 400	0,61	0,75	8	9,7	19,9	24,3	
1 400	1 600	0,7	0,85	9,1	11,1	22,7	27,7	
1 600	1 800	0,79	0,96	10,2	12,5	25,6	31,2	

Applying the recommended values prevents the inner ring from creeping, but does not ensure correct radial internal clearance in operation. Additional influences from the bearing housing fit and temperature differences between the inner and outer rings must be considered carefully when selecting the bearing radial internal clearance class (*Selecting initial internal clearance*, page 183).

<sup>1)</sup> Not valid for the SKF Drive-up Method.

<sup>2)</sup> The listed values are valid only for solid steel shafts and general applications. They are to be used as guideline values only, as it is difficult to establish an exact starting position. Also, the axial drive-up, s, differs slightly between the different bearings series.

# Designation system

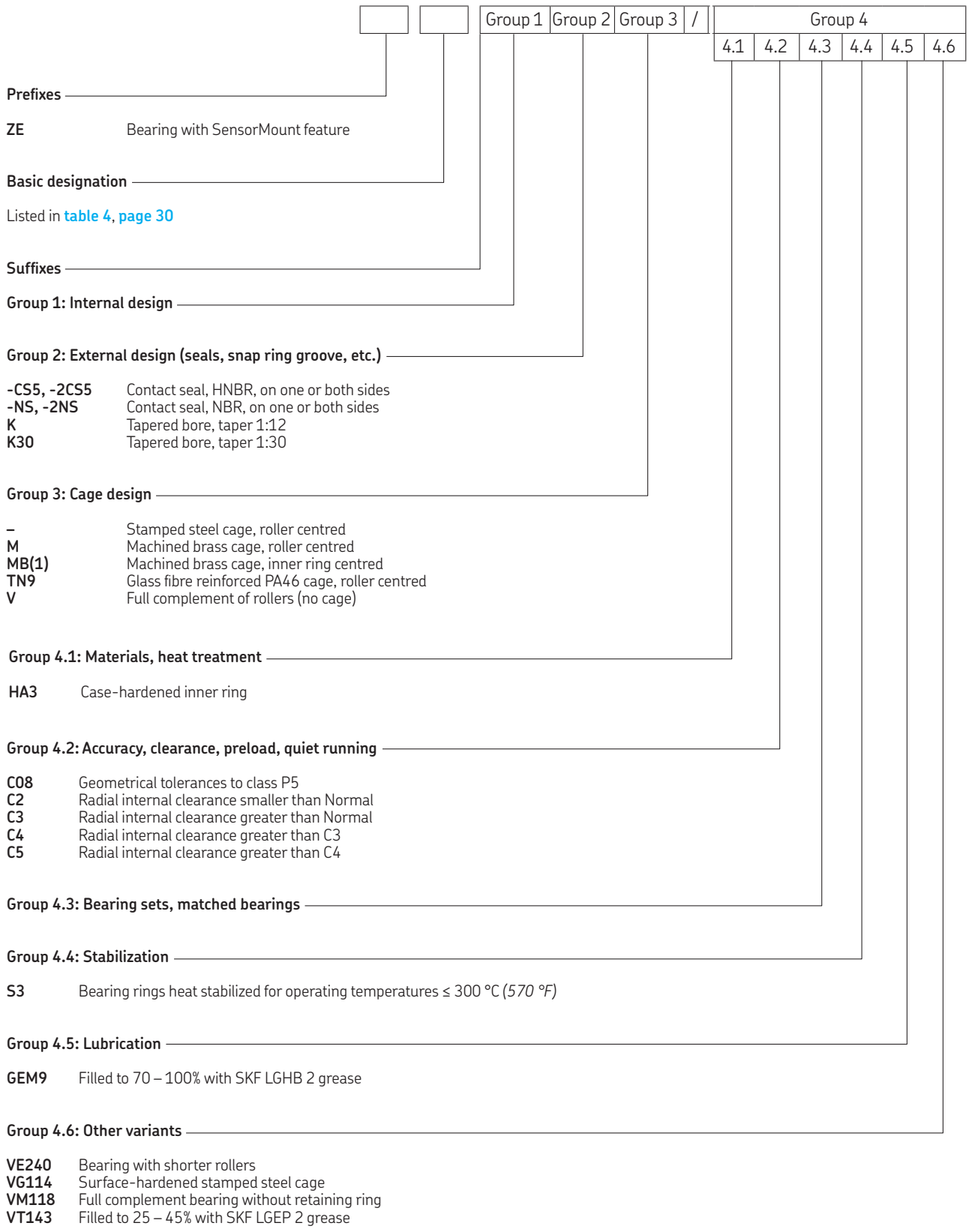



## 10.1 CARB toroidal roller bearings

d 30 – 70 mm

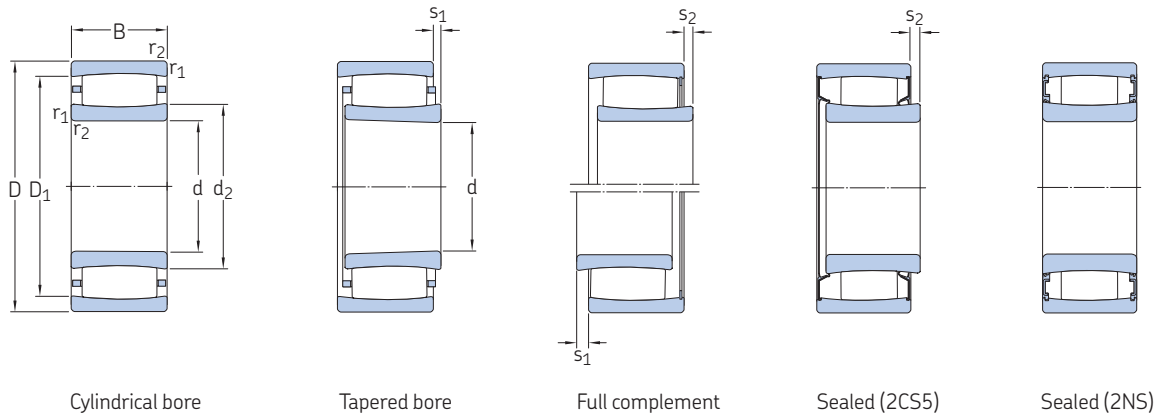

Principal dimensions			Basic load ratings		Fatigue load limit	Speed ratings		Mass	Designations	
d	D	B	dynamic	static		Reference speed	Limiting speed		Bearing with cylindrical bore	tapered bore
mm			C	C <sub>0</sub>	P <sub>u</sub>	r/min		kg	–	
30	55	45	134	180	21,2	–	3 200	0,49	▶ C 6006 V	–
	62	20	69,5	62	7,2	11 000	15 000	0,28	▶ C 2206 TN9	C 2206 KTN9
	62	20	76,5	71	8,3	–	6 000	0,29	C 2206 V	–
35	72	23	83	80	9,3	9 500	13 000	0,44	▶ C 2207 TN9	C 2207 KTN9
	72	23	95	96	11,2	–	5 300	0,46	C 2207 V	–
40	62	22	76,5	100	11,8	–	4 300	0,25	▶ C 4908 V	–
	80	23	90	86,5	10,2	8 000	11 000	0,51	▶ C 2208 TN9	C 2208 KTN9
	80	23	102	104	12,2	–	4 500	0,53	▶ C 2208 V	–
45	68	40	132	200	23,6	–	2 600	0,53	C 6909 V	–
	85	23	93	93	10,8	7 500	11 000	0,56	▶ C 2209 TN9	▶ C 2209 KTN9
	85	23	106	110	12,9	–	4 300	0,58	C 2209 V	–
50	72	22	86,5	125	14,6	–	3 600	0,29	C 4910 V	–
	72	40	140	224	26	–	2 400	0,54	▶ C 6910 V	–
	80	30	116	140	16,3	5 600	7 500	0,55	▶ C 4010 TN9	–
	80	30	137	176	20,8	–	3 000	0,58	C 4010 V	–
	90	23	98	100	11,8	7 000	9 500	0,6	▶ C 2210 TN9	▶ C 2210 KTN9
	90	23	114	122	14,3	–	3 800	0,63	C 2210 V	–
55	80	45	180	300	35,5	–	2 200	0,78	C 6911 V	–
	100	25	116	114	13,4	6 300	9 000	0,8	▶ C 2211 TN9	▶ C 2211 KTN9
	100	25	132	134	15,6	–	3 400	0,82	▶ C 2211 V	C 2211 KV
60	85	45	190	335	39	–	–	0,83	▶ C 6912-2NSV	–
	85	45	190	335	39	–	1 900	0,83	▶ C 6912 V	–
	110	28	143	156	18,3	5 600	7 500	1,1	▶ C 2212 TN9	▶ C 2212 KTN9
	110	28	166	190	22,4	–	2 800	1,15	C 2212 V	C 2212 KV
65	100	35	102	173	20,4	–	150	1,05	C 4013-2CS5V/GEM9	–
	120	31	180	180	21,2	5 300	7 500	1,45	▶ C 2213 TN9	▶ C 2213 KTN9
	120	31	204	216	25,5	–	2 400	1,5	C 2213 V	C 2213 KV
70	125	31	186	196	22,8	5 000	7 000	1,5	▶ C 2214 TN9	C 2214 KTN9
	125	31	212	228	26,5	–	2 400	1,55	C 2214 V	–
	150	51	405	430	49	3 800	5 000	4,3	▶ C 2314	C 2314 K

SKF Explorer bearing  
▶ Popular item

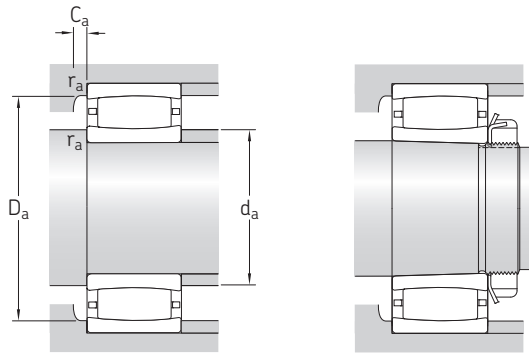

Dimensions			Abutment and fillet dimensions							Calculation factors			
d	d <sub>2</sub> ≈	D <sub>1</sub> ≈	r <sub>1,2</sub> min.	s <sub>1</sub> <sup>1)</sup> max.	s <sub>2</sub> <sup>1)</sup> max.	d <sub>a</sub> min.	d <sub>a</sub> max.	D <sub>a</sub> min.	D <sub>a</sub> max.	C <sub>a</sub> <sup>2)</sup> min.	r <sub>a</sub> max.	k <sub>1</sub>	k <sub>2</sub>
mm						mm				-			
30	38,5	47,3	1	7,9	4,9	34,6	43	-	50,4	-	1	0,102	0,096
	37,4	53,1	1	4,5	-	35,6	37,4	50,6	56,4	0,3	1	0,101	0,111
	37,4	53,1	1	4,5	1,5	35,6	49	-	56,4	-	1	0,101	0,111
35	44,8	60,7	1,1	5,7	-	42	44,8	58,5	65	0,1	1	0,094	0,121
	44,8	60,7	1,1	5,7	2,7	42	57	-	65	-	1	0,094	0,121
40	46,1	55,3	0,6	4,7	1,7	43,2	52	-	58,8	-	0,6	0,099	0,114
	52,4	69,9	1,1	7,1	-	47	52,4	67,1	73	0,3	1	0,093	0,128
	52,4	69,9	1,1	7,1	4,1	47	66	-	73	-	1	0,093	0,128
45	52	59,5	0,6	9,4	6,4	48,2	55	-	64,8	-	0,6	0,091	0,113
	55,6	73,1	1,1	7,1	-	52	55,6	70,4	78	0,3	1	0,095	0,128
	55,6	73,1	1,1	7,1	4,1	52	69	-	78	-	1	0,095	0,128
50	56,9	66,1	0,6	4,7	1,7	53,2	62	-	68,8	-	0,6	0,103	0,114
	57,5	65	0,6	9,4	6,4	53,2	61	-	68,8	-	0,6	0,093	0,113
	57,6	70,8	1	6	-	54,6	57,6	69,7	75,4	0,1	1	0,103	0,107
	57,6	70,8	1	6	3	54,6	67	-	75,4	-	1	0,103	0,107
	61,9	79,4	1,1	7,1	-	57	61,9	76,7	83	-0,8	1	0,097	0,128
	61,9	79,4	1,1	7,1	3,9	57	73	-	83	-	1	0,097	0,128
55	62,7	71,5	1	7,9	4,9	59,6	67	-	75,4	-	1	0,107	0,096
	65,8	86,7	1,5	8,6	-	64	65,8	83,1	91	0,3	1,5	0,094	0,133
	65,8	86,7	1,5	8,6	5,4	64	80	-	91	-	1,5	0,094	0,133
60	68,7	77,5	1	-	0,5	64,6	68,7	-	80,4	-	1	0,108	0,096
	68,7	77,5	1	7,9	4,7	64,6	72	-	80,4	-	1	0,108	0,096
	77,1	97,9	1,5	8,5	-	69	77,1	94,7	101	0,3	1,5	0,1	0,123
	77,1	97,9	1,5	8,5	5,3	69	91	-	101	-	1,5	0,1	0,123
65	78,6	87,5	1,1	-	5,9	71	78,6	-	94	-	1	0,071	0,181
	79	106	1,5	9,6	-	74	79	102	111	0,2	1,5	0,097	0,127
	79	106	1,5	9,6	5,3	74	97	-	111	-	1,5	0,097	0,127
70	83,7	111	1,5	9,6	-	79	83,7	107	116	0,4	1,5	0,098	0,127
	83,7	111	1,5	9,6	5,3	79	102	-	116	-	1,5	0,098	0,127
	91,4	130	2,1	9,1	-	82	106	119	138	2,2	2	0,11	0,099

<sup>1)</sup> → Verification of axial displacement, page 850

<sup>2)</sup> → Free space on both sides of the bearing, page 852, negative values used only for calculation



## 10.1 CARB toroidal roller bearings

d 75 – 110 mm

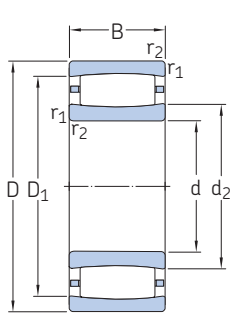

Cylindrical bore

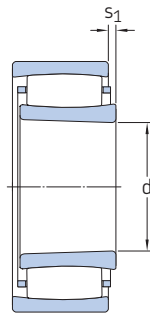

Tapered bore

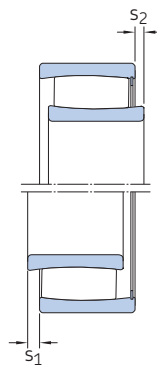

Full complement

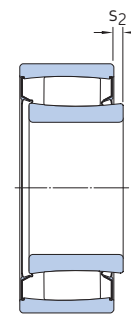

Sealed (2CS5)

Principal dimensions			Basic load ratings		Fatigue load limit	Speed ratings		Mass	Designations		
d	D	B	C	C <sub>0</sub>	P <sub>u</sub>	Reference speed	Limiting speed		Bearing with cylindrical bore	tapered bore	
mm			kN		kN	r/min		kg	–		
75	105	40	166	232	30	–	130	3,9	▶ C 5915-2CS5V/GEM9	–	
	105	40	204	325	38	–	1 900	1,1	▶ C 5915 V	–	
	105	54	204	325	37,5	–	140	1,4	C 6915-2CS5V/GEM9	–	
	105	54	204	325	37,5	–	1 900	1,4	C 6915 V/VE240	–	
	115	40	208	345	40,5	–	2 000	1,6	C 4015 V	–	
	130	31	196	208	24	4 800	6 700	1,6	▶ C 2215	▶ C 2215 K	
	130	31	220	240	28	–	2 200	1,65	C 2215 V	C 2215 KV	
	160	55	425	465	52	3 600	4 800	5,3	▶ C 2315	▶ C 2315 K	
	80	140	33	220	250	28,5	4 300	6 000	2,05	▶ C 2216	▶ C 2216 K
		140	33	255	305	34,5	–	2 000	2,15	C 2216 V	C 2216 KV
170		58	510	550	60	3 400	4 500	6,3	▶ C 2316	▶ C 2316 K	
85	150	36	275	320	35,5	4 000	5 600	2,65	▶ C 2217	▶ C 2217 K	
	180	60	540	600	64	3 200	4 300	7,4	▶ C 2317	▶ C 2317 K	
90	125	46	193	325	37,5	2 600	4 000	1,75	C 5918 MB	–	
	125	46	224	400	44	–	110	1,75	C 5918-2CS5V/GEM9	–	
	125	46	224	400	45,5	–	1 600	1,75	▶ C 5918 V	–	
95	160	40	325	380	41,5	3 800	5 300	3,3	▶ C 2218	▶ C 2218 K	
	190	64	610	695	73,5	2 800	4 000	8,65	▶ C 2318	C 2318 K	
95	200	67	610	695	73,5	2 800	4 000	10	C 2319	C 2319 K	
100	150	50	355	530	58,5	–	1 400	3,05	▶ C 4020 V	–	
	150	67	510	865	95	–	1 100	4,3	▶ C 5020 V	–	
	165	52	475	655	71	–	1 300	4,45	▶ C 3120 V	–	
	165	65	475	655	69,5	–	90	5,2	C 4120-2CS5V/GEM9	–	
	165	65	475	655	71	–	1 300	5,3	C 4120 V/VE240	–	
	180	46	415	465	49	3 600	4 800	4,95	▶ C 2220	▶ C 2220 K	
	215	73	800	880	90	2 600	3 600	12,5	▶ C 2320	▶ C 2320 K	
	110	170	60	415	585	63	–	85	4,6	C 4022-2CS5V/GEM9	–
		170	60	430	655	69,5	2 600	3 400	5,3	C 4022 MB	–
		170	60	500	800	85	–	1 200	5,2	C 4022 V	–
110	180	69	500	710	75	–	80	6,6	C 4122-2CS5V/GEM9	–	
	180	69	670	1 000	104	–	900	7,1	▶ C 4122 V	–	
	200	53	530	620	64	3 200	4 300	7	▶ C 2222	▶ C 2222 K	

SKF Explorer bearing  
▶ Popular item

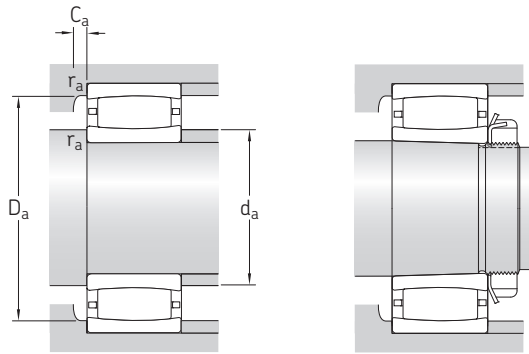

Dimensions			Abutment and fillet dimensions								Calculation factors			
d	d <sub>2</sub> ≈	D <sub>1</sub> ≈	r <sub>1,2</sub> min.	s <sub>1</sub> <sup>1)</sup> max.	s <sub>2</sub> <sup>1)</sup> max.	d <sub>a</sub> min.	d <sub>a</sub> max.	D <sub>a</sub> min.	D <sub>a</sub> max.	C <sub>a</sub> <sup>2)</sup> min.	r <sub>a</sub> max.	k <sub>1</sub>	k <sub>2</sub>	
mm						mm					-			
75	82,9	96,1	1	-	5	79,6	84,1	-	100	-	1	0,083	0,142	
	83,6	95,5	1	9,4	6,2	79,6	89	-	100	-	1	0,098	0,114	
	83,6	95,5	1	-	7,1	79,6	83	-	100	-	1	0,073	0,154	
75	83,6	95,5	1	9,2	9,2	79,6	88	-	100	-	1	0,073	0,154	
	88,7	101	1,1	9,4	5,1	81	94	-	109	-	1	0,099	0,114	
	88,5	116	1,5	9,6	-	84	98,3	106	121	1,2	1,5	0,099	0,127	
	88,5	116	1,5	9,6	5,3	84	107	-	121	-	1,5	0,099	0,127	
75	98,5	137	2,1	13,1	-	87	113	126	148	2,2	2	0,103	0,107	
	80	98,1	125	2	9,1	-	91	107	116	129	1,2	2	0,104	0,121
		98,1	125	2	9,1	4,8	91	116	-	129	-	2	0,104	0,121
80	102	146	2,1	10,1	-	92	119	133	158	2,4	2	0,107	0,101	
	85	103	133	2	7,1	-	96	114	123	139	1,3	2	0,114	0,105
110		153	3	12,1	-	99	126	141	166	2,4	2,5	0,105	0,105	
90	100	113	1,1	2,9	-	96	99	113	119	-0,9	1	0	0,131	
	102	113	1,1	-	4,5	96	101	-	119	-	1	0,089	0,131	
	102	113	1,1	15,4	11,1	96	106	-	119	-	1	0,089	0,131	
90	111	144	2	9,5	-	101	124	133	149	1,4	2	0,104	0,117	
	119	166	3	9,6	-	104	138	154	176	2	2,5	0,108	0,101	
95	119	166	3	12,6	-	109	138	154	186	2,1	2,5	0,103	0,106	
100	113	135	1,5	14	9,7	107	126	-	143	-	1,5	0,098	0,118	
	114	136	1,5	9,3	5	107	127	-	143	-	1,5	0,112	0,094	
	119	150	2	10,1	4,7	111	136	-	154	-	2	0,112	0,1	
100	120	148	2	-	7,3	111	119	-	154	-	2	0,09	0,125	
	120	148	2	17,7	17,7	111	135	-	154	-	2	0,09	0,125	
	118	157	2,1	10,1	-	112	134	146	168	0,9	2	0,108	0,11	
	126	185	3	11	-	114	150	168	201	3,2	2,5	0,113	0,096	
110	128	155	2	-	7,9	119	127	-	161	-	2	0,142	0,083	
	126	150	2	4,8	-	120	125	146	160	1,3	2	0	0,103	
	126	150	2	12	6,6	120	136	-	160	-	2	0,107	0,103	
	130	161	2	-	8,2	121	130	-	169	-	2	0,086	0,133	
110	132	163	2	11,4	4,6	121	149	-	169	-	2	0,111	0,097	
	132	176	2,1	11,1	-	122	150	161	188	1,9	2	0,113	0,103	

<sup>1)</sup> → Verification of axial displacement, page 850

<sup>2)</sup> → Free space on both sides of the bearing, page 852, negative values used only for calculation



## 10.1 CARB toroidal roller bearings

d 120 – 170 mm

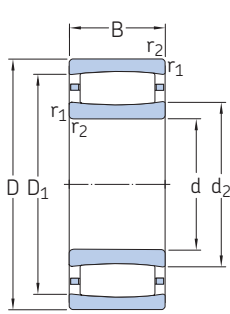

Cylindrical bore

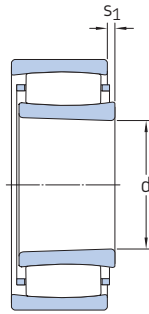

Tapered bore

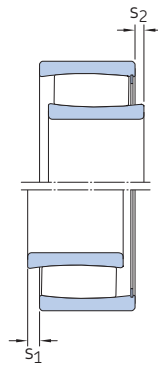

Full complement

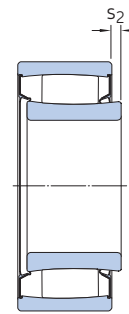

Sealed (2CS5)

Principal dimensions			Basic load ratings		Fatigue load limit	Speed ratings		Mass	Designations		
d	D	B	C	C <sub>0</sub>		Reference speed	Limiting speed		Bearing with cylindrical bore	tapered bore	
mm			kN		kN	r/min		kg	–		
120	180	46	430	640	65,5	–	1 400	4,1	C 3024 V	–	
	180	60	430	640	67	–	80	5,1	C 4024-2CS5V/GEM9	–	
	180	60	430	640	65,5	–	1 400	5,05	C 4024 V/VE240	C 4024 K30V/VE240	
120	180	60	530	880	91,5	–	1 100	5,55	▶ C 4024 V	C 4024 K30V	
	200	80	780	1 120	114	–	750	10	C 4124 V	–	
	215	76	750	980	98	2 400	3 200	12	▶ C 3224	▶ C 3224 K	
130	200	69	550	830	85	–	70	7,5	C 4026-2CS5V/GEM9	–	
	200	69	620	930	93	2 200	2 800	7,85	▶ C 4026	C 4026 K30	
	200	69	720	1 120	112	–	850	8,15	▶ C 4026 V	C 4026 K30V	
130	210	80	750	1 100	108	–	70	10,5	C 4126-2CS5V/GEM9	–	
	230	64	735	930	91,5	2 800	3 800	11,5	▶ C 2226	▶ C 2226 K	
	280	93	980	1 220	114	2 400	3 200	27	C 2326 K/VE240	–	
140	210	69	750	1 220	120	–	800	8,6	▶ C 4028 V	C 4028 K30V	
	225	85	780	1 200	116	–	63	12,5	C 4128-2CS5V/GEM9	–	
	225	85	780	1 200	116	–	800	12,5	C 4128 V/VE240	–	
140	250	68	830	1 060	102	2 400	3 200	14	▶ C 2228	▶ C 2228 K	
	150	225	56	540	850	81,5	2 400	3 200	8,45	C 3030 MB	–
		225	56	585	960	93	–	1 000	8	C 3030 V	C 3030 KV
225		75	585	965	93	–	63	10	C 4030-2CS5V/GEM9	–	
150	225	75	780	1 320	127	–	750	10,5	▶ C 4030 V	C 4030 K30V	
	250	80	880	1 290	122	2 000	2 800	15,5	C 3130	C 3130 K	
	250	100	1 220	1 860	176	–	450	20	▶ C 4130 V	–	
150	270	73	980	1 220	114	2 400	3 200	18	▶ C 2230	C 2230 K	
	160	240	80	765	1 160	110	1 700	2 400	12,5	▶ C 4032	C 4032 K30
		240	80	830	1 290	122	–	60	12,5	C 4032-2CS5V/GEM9	–
240		80	915	1 460	140	–	600	13	▶ C 4032 V	C 4032 K30V	
160	270	86	1 000	1 400	129	1 900	2 600	21,5	C 3132	C 3132 K	
	290	104	1 370	1 830	170	1 800	2 400	29,5	C 3232	C 3232 K	
170	260	67	750	1 080	100	2 200	2 800	12,5	C 3034 M	–	
	260	90	1 140	1 860	173	–	500	17,5	▶ C 4034 V	C 4034 K30V	
	310	86	1 270	1 630	146	1 900	2 600	28	C 2234	C 2234 K	

SKF Explorer bearing

▶ Popular item

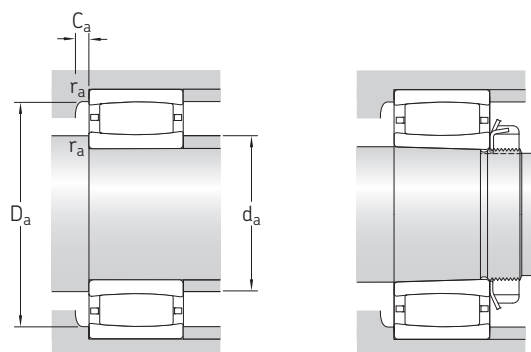

Dimensions			Abutment and fillet dimensions							Calculation factors			
d	d <sub>2</sub> ≈	D <sub>1</sub> ≈	r <sub>1,2</sub> min.	s <sub>1</sub> <sup>1)</sup> max.	s <sub>2</sub> <sup>1)</sup> max.	d <sub>a</sub> min.	d <sub>a</sub> max.	D <sub>a</sub> min.	D <sub>a</sub> max.	C <sub>a</sub> <sup>2)</sup> min.	r <sub>a</sub> max.	k <sub>1</sub>	k <sub>2</sub>
mm						mm				-			
<b>120</b>	138	166	2	10,6	3,8	130	154	-	170	-	2	0,111	0,109
	140	164	2	-	7,5	129	139	-	171	-	2	0,085	0,142
	139	164	2	17,8	17,8	130	152	-	170	-	2	0,085	0,142
	140	164	2	12	5,2	130	152	-	170	-	2	0,109	0,103
	140	176	2	18	11,2	131	160	-	189	-	2	0,104	0,103
	149	190	2,1	17,1	-	132	162	179	203	2,4	2	0,103	0,108
<b>130</b>	152	182	2	-	8,2	139	151	-	191	-	2	0,089	0,133
	149	181	2	11,4	-	140	157	174	190	1,9	2	0,113	0,097
	149	181	2	11,4	4,6	140	167	-	190	-	2	0,113	0,097
	153	190	2	-	7,5	141	152	-	199	-	2	0,09	0,126
	152	199	3	9,6	-	144	171	185	216	1,1	2,5	0,113	0,101
	179	234	4	31,2	-	-	-	216	263	-7,5	3	0,093	0,122
<b>140</b>	161	193	2	11,4	5,9	150	177	-	200	-	2	0,115	0,097
	167	204	2,1	-	8,9	152	166	-	213	-	2	0,086	0,134
	166	204	2,1	9,7	9,7	152	189	-	213	-	2	0,086	0,134
	173	223	3	13,7	-	154	191	207	236	2,3	2,5	0,109	0,108
	173	204	2,1	8,7	-	161	172	198	214	1,3	2	0	0,108
<b>150</b>	174	204	2,1	14,1	7,3	161	190	-	214	-	2	0,113	0,108
	175	204	2,1	-	10,8	161	174	-	214	-	2	0,084	0,144
	173	204	2,1	17,4	10,6	161	189	-	214	-	2	0,107	0,106
	182	226	2,1	13,9	-	162	196	214	238	2,3	2	0,12	0,092
	179	222	2,1	20	10,1	162	204	-	238	-	2	0,105	0,103
	177	236	3	11,2	-	164	202	215	256	2,5	2,5	0,119	0,096
<b>160</b>	181	217	2,1	18,1	-	171	190	209	229	2,2	2	0,109	0,103
	180	218	2,1	-	7,7	171	180	-	229	-	2	0,093	0,126
	181	217	2,1	18,1	8,2	171	199	-	229	-	2	0,109	0,103
	191	240	2,1	10,3	-	172	208	229	258	2,4	2	0,112	0,099
	194	256	3	19,3	-	174	218	242	276	2,6	2,5	0,112	0,096
<b>170</b>	195	236	2,1	19	-	181	210	226	249	1,2	2	0,105	0,117
	195	236	2,1	17,1	7,2	181	218	-	249	-	2	0,108	0,103
	209	274	4	16,4	-	187	233	254	293	3	3	0,114	0,1

<sup>1)</sup> → Verification of axial displacement, page 850  
<sup>2)</sup> → Free space on both sides of the bearing, page 852, negative values used only for calculation

## 10.1 CARB toroidal roller bearings

d 180 – 360 mm

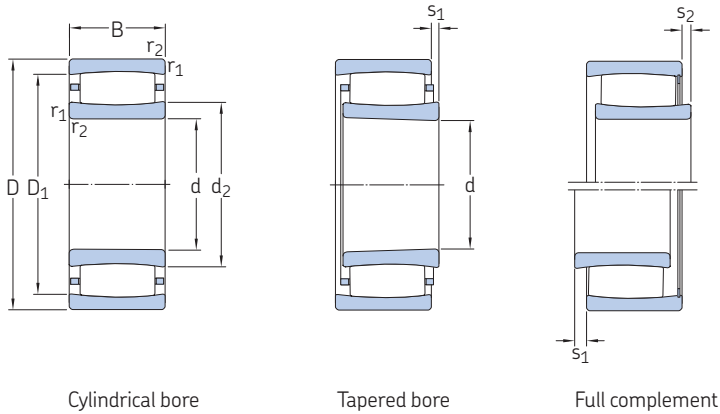

Principal dimensions			Basic load ratings		Fatigue load limit	Speed ratings		Mass	Designations	
d	D	B	C	C <sub>0</sub>	P <sub>u</sub>	Reference speed	Limiting speed		Bearing with cylindrical bore	tapered bore
mm			kN		kN	r/min		kg	–	
180	280	74	880	1 340	122	2 000	2 600	17	C 3036	C 3036 K
	280	100	1 320	2 120	196	–	430	23,5	C 4036 V	–
	300	96	1 250	1 730	156	1 700	2 400	26,5	▶ C 3136	▶ C 3136 K
	300	118	1 760	2 700	240	–	220	34,5	C 4136 V	–
	320	112	1 530	2 200	193	1 500	2 000	38	C 3236	C 3236 K
	320	128	2 000	2 500	208	1 500	2 000	57,5	C 2244	C 2244 K
190	290	75	930	1 460	132	1 800	2 400	17,5	C 3038	C 3038 K
	320	104	1 700	2 550	224	–	190	34	C 3138 V	C 3138 KV
	340	92	1 370	1 730	153	1 800	2 400	34,5	▶ C 2238	C 2238 K
200	310	82	1 120	1 730	153	1 700	2 400	22,5	▶ C 3040	C 3040 K
	310	109	1 630	2 650	236	–	260	30,5	C 4040 V	–
	340	112	1 600	2 320	200	1 500	2 000	41	▶ C 3140	▶ C 3140 K
220	340	90	1 320	2 040	176	1 600	2 200	29,5	▶ C 3044	▶ C 3044 K
	340	118	1 930	3 250	280	–	200	40	C 4044 V	C 4044 K30V
	370	120	1 900	2 900	245	1 400	1 800	52	▶ C 3144	▶ C 3144 K
240	360	92	1 340	2 160	183	1 500	2 000	32	C 3048	C 3048 K
	400	128	2 320	3 450	285	1 300	1 700	64	▶ C 3148	▶ C 3148 K
260	400	104	1 760	2 850	232	1 300	1 800	47	C 3052	C 3052 K
	440	144	2 650	4 050	325	1 100	1 500	88	▶ C 3152	▶ C 3152 K
280	420	106	1 860	3 100	250	1 200	1 600	50,5	C 3056	C 3056 K
	460	146	2 850	4 500	355	1 100	1 400	94,5	C 3156	C 3156 K
300	460	118	2 160	3 750	290	1 100	1 500	72	C 3060 M	C 3060 KM
	460	160	2 900	4 900	390	900	1 200	95,5	C 4060 M	C 4060 K30M
	500	160	3 250	5 200	400	950	1 300	125	C 3160	C 3160 K
320	480	121	2 280	4 000	305	1 000	1 400	78	C 3064 M	C 3064 KM
	540	176	4 150	6 300	480	900	1 300	164	▶ C 3164 M	C 3164 KM
340	520	133	2 900	5 000	375	950	1 300	100	C 3068 M	C 3068 KM
	580	190	4 900	7 500	560	850	1 100	205	C 3168 M	C 3168 KM
	580	243	5 600	9 150	680	670	900	271	C 4168 K30MB	–
360	480	90	1 760	3 250	245	1 000	1 400	45	C 3972 M	C 3972 KM
	540	134	2 900	5 000	375	900	1 300	106	C 3072 M	C 3072 KM
	600	192	5 000	8 000	585	800	1 100	220	C 3172 M	C 3172 KM

SKF Explorer bearing  
▶ Popular item

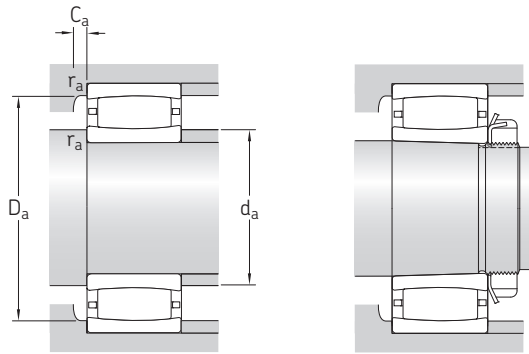

Dimensions			Abutment and fillet dimensions								Calculation factors		
d	d <sub>2</sub> ≈	D <sub>1</sub> ≈	r <sub>1,2</sub> min.	s <sub>1</sub> <sup>1)</sup> max.	s <sub>2</sub> <sup>1)</sup> max.	d <sub>a</sub> min.	d <sub>a</sub> max.	D <sub>a</sub> min.	D <sub>a</sub> max.	C <sub>a</sub> <sup>2)</sup> min.	r <sub>a</sub> max.	k <sub>1</sub>	k <sub>2</sub>
mm						mm					-		
<b>180</b>	209	251	2,1	15,1	-	191	223	239	269	2	2	0,112	0,105
	203	247	2,1	20,1	10,2	191	229	-	269	-	2	0,107	0,103
	210	266	3	23,2	-	194	231	252	286	2,2	2,5	0,102	0,111
	211	265	3	20	10,1	194	223	-	286	-	2,5	0,1	0,108
	228	289	4	27,3	-	197	249	271	303	3,2	3	0,107	0,104
	<b>190</b>	225	266	2,1	16,1	-	201	238	254	279	1,9	2	0,113
228		289	3	19	9,1	204	267	-	306	-	2,5	0,115	0,096
224		296	4	22,5	-	207	254	275	323	1,6	3	0,108	0,108
<b>200</b>	235	285	2,1	15,2	-	211	250	272	299	2,9	2	0,123	0,095
	228	280	2,1	21	11,1	211	263	-	299	-	2	0,11	0,101
	244	305	3	27,3	-	214	264	288	326	-0,6	2,5	0,108	0,104
<b>220</b>	257	310	3	17,2	-	233	274	295	327	3,1	2,5	0,114	0,104
	251	306	3	20	10,1	233	284	-	327	-	2,5	0,115	0,095
	268	333	4	22,3	-	237	290	315	353	3,5	3	0,114	0,097
	259	350	4	20,5	-	237	298	321	383	1,7	3	0,113	0,101
<b>240</b>	276	329	3	19,2	-	253	293	312	347	1,3	2,5	0,113	0,106
	281	357	4	20,4	-	257	309	334	383	3,7	3	0,116	0,095
<b>260</b>	305	367	4	19,3	-	275	326	349	385	3,4	3	0,122	0,096
	314	394	4	26,4	-	277	341	371	423	4,1	3	0,115	0,096
<b>280</b>	328	389	4	21,3	-	295	352	373	405	1,8	3	0,121	0,098
	336	416	5	28,4	-	300	363	392	440	4,1	4	0,115	0,097
<b>300</b>	351	417	4	20	-	315	376	402	445	1,7	3	0,123	0,095
	338	410	4	30,4	-	315	362	396	445	2,8	3	0,105	0,106
	362	448	5	30,5	-	320	392	422	480	4,9	4	0,106	0,106
<b>320</b>	375	441	4	23,3	-	335	398	426	465	1,8	3	0,121	0,098
	371	477	5	26,7	-	340	411	452	520	4,2	4	0,114	0,096
<b>340</b>	394	475	5	25	-	358	430	454	502	2,1	4	0,12	0,099
	402	517	5	25,9	-	360	446	489	560	4,2	4	0,118	0,093
	403	514	5	20,2	-	-	-	487	560	10,7	4	0	0,096
<b>360</b>	394	450	3	17,2	-	373	409	435	467	1,6	2,5	0,127	0,104
	416	497	5	26,4	-	378	448	476	522	2	4	0,12	0,099
	423	537	5	27,9	-	380	464	507	580	3,9	4	0,117	0,094

<sup>1)</sup> → Verification of axial displacement, page 850

<sup>2)</sup> → Free space on both sides of the bearing, page 852, negative values used only for calculation





## 10.1 CARB toroidal roller bearings

d 380 – 630 mm

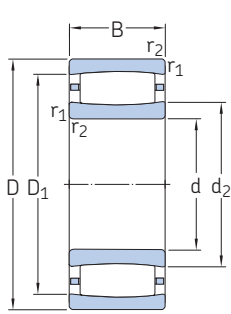

Cylindrical bore

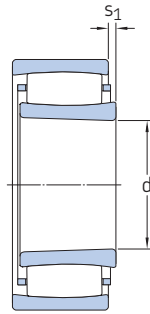

Tapered bore

Principal dimensions			Basic load ratings		Fatigue load limit	Speed ratings		Mass	Designations	
d	D	B	C	C <sub>0</sub>	P <sub>u</sub>	Reference speed	Limiting speed		Bearing with cylindrical bore	tapered bore
mm			kN		kN	r/min		kg	–	
380	560	135	3 000	5 200	380	900	1 200	110	C 3076 M	C 3076 KM
	620	194	4 400	7 200	520	750	1 000	243	C 3176 MB	C 3176 KMB
400	540	106	2 120	4 000	290	900	1 300	66,5	C 3980 KM	–
	600	148	3 650	6 200	450	800	1 100	145	C 3080 M	C 3080 KM
	650	200	4 800	8 300	585	700	950	258	C 3180 M	C 3180 KM
420	560	106	2 160	4 250	310	850	1 200	72	C 3984 M	C 3984 KM
	620	150	3 800	6 400	455	800	1 100	150	C 3084 M	C 3084 KM
	700	224	6 000	10 400	720	670	900	355	C 3184 M	C 3184 KM
440	650	157	3 750	6 400	450	750	1 000	190	C 3088 MB	C 3088 KMB
	720	226	6 700	11 400	780	630	850	385	C 3188 MB	C 3188 KMB
	720	280	7 500	12 900	900	500	670	471	C 4188 MB	C 4188 K30MB
460	680	163	4 000	7 500	520	700	950	205	C 3092 M	C 3092 KM
	760	240	6 800	12 000	815	600	800	435	C 3192 M	C 3192 KM
	760	300	8 650	15 000	1 020	480	630	571	C 4192 MB	C 4192 K30MB
480	830	296	9 300	15 000	1 000	530	750	735	C 3292 MB	C 3292 KMB
	650	128	3 100	6 100	425	750	1 000	120	C 3996 M	–
	700	165	4 050	7 800	530	670	900	215	C 3096 M	C 3096 KM
500	790	248	6 950	12 500	830	560	750	523	C 3196 MB	C 3196 KMB
	670	128	3 150	6 300	430	700	950	125	C 39/500 M	C 39/500 KM
	720	167	4 250	8 300	560	630	900	225	C 30/500 M	–
530	830	264	7 500	12 700	850	530	750	560	C 31/500 M	C 31/500 KM
	830	325	9 800	17 600	1 160	430	560	710	C 41/500 M	C 41/500 K30M
	780	185	5 100	9 500	630	600	800	300	C 30/530 M	C 30/530 KM
560	870	272	8 800	15 600	1 020	500	670	636	C 31/530 M	C 31/530 KM
	750	140	3 600	7 350	490	600	850	175	C 39/560 M	C 39/560 KM
	820	195	5 600	11 000	720	530	750	350	C 30/560 M	C 30/560 KM
600	920	355	10 400	19 600	1 270	380	500	989	C 41/560 K30MB	–
	870	200	6 300	12 200	780	500	700	395	C 30/600 M	C 30/600 KM
	980	300	10 200	18 000	1 140	430	600	929	C 31/600 MB	C 31/600 KMB
630	980	375	12 900	23 200	1 460	340	450	1 150	C 41/600 MB	C 41/600 K30MB
	850	165	4 650	10 000	640	530	700	275	C 39/630 M	C 39/630 KM
	920	212	6 800	12 900	815	480	670	470	C 30/630 M	C 30/630 KM
	1 030	315	11 800	20 800	1 290	400	560	1 090	C 31/630 MB	C 31/630 KMB

SKF Explorer bearing

► Popular item

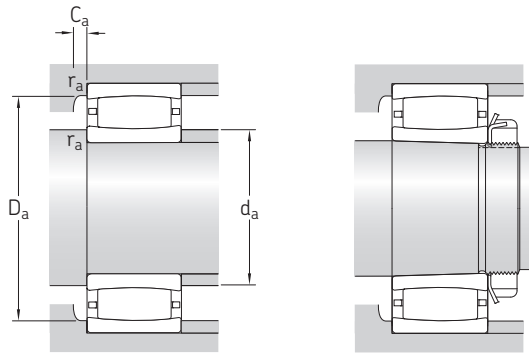

Dimensions			Abutment and fillet dimensions								Calculation factors		
d	d <sub>2</sub> ≈	D <sub>1</sub> ≈	r <sub>1,2</sub> min.	s <sub>1</sub> <sup>1)</sup> max.	s <sub>2</sub> <sup>1)</sup> max.	d <sub>a</sub> min.	d <sub>a</sub> max.	D <sub>a</sub> min.	D <sub>a</sub> max.	C <sub>a</sub> <sup>2)</sup> min.	r <sub>a</sub> max.	k <sub>1</sub>	k <sub>2</sub>
mm						mm					-		
380	431	512	5	27	-	398	462	491	542	2	4	0,12	0,1
	446	551	5	25,4	-	400	445	526	600	7,3	4	0	0,106
400	439	501	4	21	-	-	-	487	525	1,8	3	0,13	0,098
	457	554	5	30,6	-	418	486	523	582	2,1	4	0,121	0,099
	488	589	6	50,7	-	426	525	566	624	4	5	0,106	0,109
420	461	523	4	21,3	-	435	484	510	545	1,8	3	0,132	0,098
	475	571	5	32,6	-	438	513	544	602	2,2	4	0,12	0,1
	507	618	6	34,8	-	446	544	592	674	3,8	5	0,113	0,098
440	490	587	6	24,6	-	463	489	563	627	1,7	5	0	0,105
	522	647	6	16	-	466	521	613	694	7,5	5	0	0,099
	510	637	6	27,8	-	466	509	606	694	7,3	5	0	0,1
460	539	624	6	33,5	-	483	570	604	657	2,3	5	0,114	0,108
	559	679	7,5	51	-	492	603	651	728	4,2	6	0,108	0,105
	537	671	7,5	23,3	-	477	536	638	728	12,6	6	0	0,097
	555	720	7,5	32,4	-	492	554	676	798	11	6	0	0,106
480	528	604	5	20,4	-	498	552	585	632	2	4	0,133	0,095
	555	640	6	35,5	-	503	586	620	677	2,3	5	0,113	0,11
	578	701	7,5	35,1	-	512	577	673	758	8,7	6	0	0,109
500	555	632	5	20,4	-	518	580	614	652	2	4	0,135	0,095
	571	656	6	37,5	-	523	600	637	697	2,3	5	0,113	0,111
	605	738	7,5	75,3	-	532	654	706	798	-11,7	6	0,099	0,116
	600	740	7,5	46,3	-	532	637	721	798	5,9	6	0,115	0,093
530	601	705	6	35,7	-	553	638	681	757	2,5	5	0,12	0,101
	635	781	7,5	44,4	-	562	685	745	838	5,4	6	0,115	0,097
560	621	701	5	32,4	-	578	648	682	732	2,3	4	0,128	0,104
	659	761	6	45,7	-	583	696	736	797	2,7	5	0,116	0,106
	664	802	7,5	23	-	-	-	770	888	13,8	6	0	0,101
600	692	805	6	35,9	-	623	728	776	847	2,7	5	0,125	0,098
	705	871	7,5	26,1	-	632	704	827	948	5,1	6	0	0,107
	697	869	7,5	24,6	-	632	696	823	948	5,5	6	0	0,097
630	699	785	6	35,5	-	653	723	766	827	2,4	5	0,121	0,11
	716	840	7,5	48,1	-	658	759	807	892	2,9	6	0,118	0,104
	741	916	7,5	23,8	-	662	740	868	998	5,7	6	0	0,102

<sup>1)</sup> → Verification of axial displacement, page 850

<sup>2)</sup> → Free space on both sides of the bearing, page 852, negative values used only for calculation



## 10.1 CARB toroidal roller bearings

d 670 – 1 700 mm

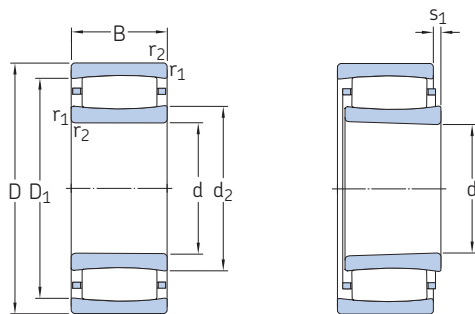

Cylindrical bore

Tapered bore

Principal dimensions			Basic load ratings		Fatigue load limit	Speed ratings		Mass	Designations	
d	D	B	dynamic	static		Reference speed	Limiting speed		Bearing with cylindrical bore	tapered bore
mm			C	C <sub>0</sub>	P <sub>u</sub>	r/min		kg	–	
670	980	230	8 150	16 300	1 000	430	600	590	C 30/670 M	▶ C 30/670 KM
	1 090	336	11 800	21 200	1 290	380	500	1 300	C 31/670 MB	C 31/670 KMB
	1 090	412	16 000	29 000	1 760	300	400	1 570	C 41/670 MB	C 41/670 K30MB
710	950	180	6 000	12 500	780	450	630	360	C 39/710 M	C 39/710 KM
	1 030	236	8 800	17 300	1 060	400	560	655	C 30/710 M	C 30/710 KM
	1 030	315	10 600	21 600	1 320	320	430	865	C 40/710 M	C 40/710 K30M
	1 150	345	13 400	25 500	1 530	340	480	1 470	C 31/710 MB	C 31/710 KMB
750	1 000	185	6 100	13 400	815	430	560	410	C 39/750 M	C 39/750 KM
	1 090	250	9 500	19 300	1 160	380	530	838	C 30/750 MB	▶ C 30/750 KMB
	1 220	365	16 000	30 500	1 800	320	450	1 800	C 31/750 MB	C 31/750 KMB
800	1 060	195	6 400	14 600	880	380	530	480	C 39/800 M	–
	1 150	258	9 300	19 300	1 140	360	480	941	C 30/800 MB	C 30/800 KMB
850	1 120	200	7 350	16 300	960	360	480	540	C 39/850 M	C 39/850 KM
	1 220	272	11 600	24 500	1 430	320	450	1 110	C 30/850 MB	C 30/850 KMB
900	1 280	280	12 700	26 500	1 530	300	400	1 200	C 30/900 MB	C 30/900 KMB
950	1 360	300	13 200	28 500	1 600	280	380	1 480	C 30/950 MB	–
1 000	1 420	308	13 700	30 500	1 700	260	360	1 680	C 30/1000 MB	–
	1 580	462	20 400	45 500	2 500	220	300	3 800	C 31/1000 MB	C 31/1000 KMB
1 060	1 400	250	11 000	26 000	1 430	260	360	1 120	C 39/1060 MB	C 39/1060 KMB
1 120	1 460	335	13 200	31 500	1 700	200	260	1 630	C 49/1120 MB1	–
1 180	1 540	272	13 400	33 500	1 800	220	300	1 400	▶ C 39/1180 MB	–
1 500	1 950	335	19 600	48 000	2 400	140	200	2 710	▶ C 39/1500 MB	–
1 700	2 180	355	24 000	62 000	3 000	110	150	3 510	C 39/1700 MB	–

SKF Explorer bearing

▶ Popular item

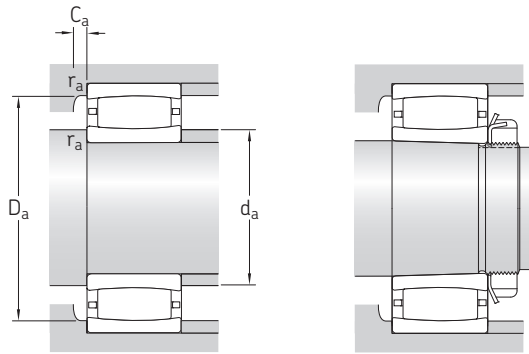

Dimensions			Abutment and fillet dimensions								Calculation factors		
d	d <sub>2</sub> ≈	D <sub>1</sub> ≈	r <sub>1,2</sub> min.	s <sub>1</sub> <sup>1)</sup> max.	s <sub>2</sub> <sup>1)</sup> max.	d <sub>a</sub> min.	d <sub>a</sub> max.	D <sub>a</sub> min.	D <sub>a</sub> max.	C <sub>a</sub> <sup>2)</sup> min.	r <sub>a</sub> max.	k <sub>1</sub>	k <sub>2</sub>
mm						mm					-		
<b>670</b>	775	905	7,5	41,1	-	698	820	874	952	2,9	6	0,121	0,101
	792	964	7,5	41	-	702	791	922	1 058	11,4	6	0	0,109
	779	967	7,5	37,2	-	702	778	920	1 058	16,7	6	0	0,097
<b>710</b>	772	877	6	30,7	-	733	797	847	927	2,7	5	0,131	0,098
	806	946	7,5	47,3	-	738	853	908	1 002	3,2	6	0,119	0,104
	803	935	7,5	51,2	-	738	843	911	1 002	4,4	6	0,113	0,101
	842	1 013	9,5	47,8	-	750	841	973	1 110	11,1	8	0	0,111
<b>750</b>	830	934	6	35,7	-	773	856	908	977	2,7	5	0,131	0,101
	854	993	7,5	28,6	-	778	852	961	1 062	7,4	6	0	0,11
	884	1 077	9,5	33	-	790	883	1 025	1 180	9,3	8	0	0,094
<b>800</b>	888	990	6	45,7	-	823	917	967	1 037	2,9	5	0,126	0,106
	908	1 048	7,5	45,9	-	828	905	1 020	1 122	7,2	6	0	0,114
<b>850</b>	940	1 053	6	35,9	-	873	963	1 025	1 097	2,9	5	0,135	0,098
	964	1 113	7,5	24	-	878	963	1 077	1 192	7,7	6	0	0,097
<b>900</b>	1 005	1 173	7,5	24,8	-	928	1 003	1 126	1 252	9	6	0	0,1
<b>950</b>	1 075	1 241	7,5	37,8	-	978	1 073	1 204	1 332	8,7	6	0	0,107
<b>1 000</b>	1 130	1 295	7,5	44,9	-	1 028	1 128	1 260	1 392	8,5	6	0	0,11
	1 191	1 372	12	70,1	-	1 048	1 189	1 338	1 532	15	10	0	0,108
<b>1 060</b>	1 168	1 308	7,5	38,4	-	1 088	1 164	1 282	1 372	6	6	0	0,11
<b>1 120</b>	1 225	1 362	7,5	76,1	-	1 148	1 220	1 344	1 432	47,6	6	0	0,12
<b>1 180</b>	1 291	1 439	7,5	19,6	-	1 208	1 289	1 405	1 512	6,2	6	0	0,097
<b>1 500</b>	1 636	1 831	9,5	35	-	1 534	1 633	1 788	1 916	9,3	8	0	0,096
<b>1 700</b>	1 841	2 053	9,5	40,6	-	1 734	1 837	2 008	2 146	8,4	8	0	0,103

<sup>1)</sup> → Verification of axial displacement, page 850

<sup>2)</sup> → Free space on both sides of the bearing, page 852, negative values used only for calculation



## 10.2 CARB toroidal roller bearings on an adapter sleeve

$d_1$  25 – 410 mm

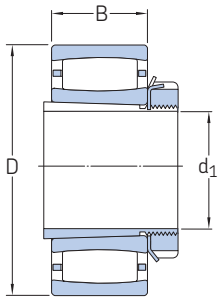

Bearing on an  
H.. sleeve

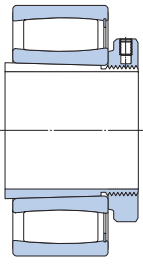

Bearing on an  
H.. E sleeve

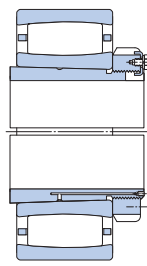

Bearing on an  
OH.. H sleeve

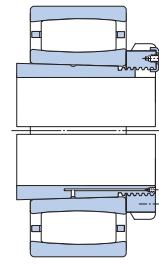

Bearing on an  
OH.. HE sleeve

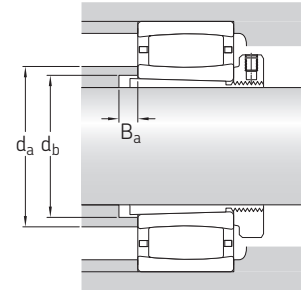

Principal dimensions			Abutment and fillet dimensions			Mass Bearing + sleeve	Designations Bearing <sup>1)</sup>	Sleeve <sup>2)</sup>
$d_1$	D	B	$d_a$ max.	$d_b$ min.	$B_a$ min.			
mm			mm			kg	–	
25	62	20	37,4	33	5	0,37	<b>C 2206 KTN9</b>	H 306 E
30	72	23	44,8	39	5	0,59	<b>C 2207 KTN9</b>	H 307 E
35	80	23	52,4	44	5	0,69	<b>C 2208 KTN9</b>	H 308 E
40	85	23	55,6	50	7	0,76	▶ <b>C 2209 KTN9</b>	H 309 E
45	90	23	61,9	55	9	0,85	▶ <b>C 2210 KTN9</b>	H 310 E
50	100	25	65,8	60	10	1,1	▶ <b>C 2211 KTN9</b>	H 311 E
	100	25	80	60	10	1,15	<b>C 2211 KV</b>	H 311 E
55	110	28	77,1	65	9	1,45	▶ <b>C 2212 KTN9</b>	H 312 E
	110	28	91	65	9	1,5	<b>C 2212 KV</b>	H 312
60	120	31	79	70	8	1,8	▶ <b>C 2213 KTN9</b>	H 313 E
	120	31	97	70	8	1,9	<b>C 2213 KV</b>	H 313
	125	31	83,7	75	9	2,1	<b>C 2214 KTN9</b>	H 314 E
65	150	51	106	76	6	5,1	<b>C 2314 K</b>	H 2314
	130	31	98,3	80	12	2,3	▶ <b>C 2215 K</b>	H 315 E
	130	31	107	80	12	2,4	<b>C 2215 KV</b>	H 315
70	160	55	113	82	6	6,2	▶ <b>C 2315 K</b>	H 2315
	140	33	107	85	12	2,9	▶ <b>C 2216 K</b>	H 316 E
	140	33	116	85	12	3	<b>C 2216 KV</b>	H 316
75	170	58	119	88	6	7,4	▶ <b>C 2316 K</b>	H 2316
	150	36	114	91	12	3,7	▶ <b>C 2217 K</b>	H 317 E
	180	60	126	94	7	8,5	▶ <b>C 2317 K</b>	H 2317
80	160	40	124	96	10	4,5	▶ <b>C 2218 K</b>	H 318 E
	190	64	138	100	7	10	<b>C 2318 K</b>	H 2318
85	200	67	138	105	7	11,5	<b>C 2319 K</b>	H 2319
90	180	46	134	108	8	6,3	▶ <b>C 2220 K</b>	H 320 E
	215	73	150	110	7	14,5	▶ <b>C 2320 K</b>	H 2320
100	200	53	150	118	6	8,8	▶ <b>C 2222 K</b>	H 322 E
110	215	76	162	131	17	14	▶ <b>C 3224 K</b>	H 2324 L

SKF Explorer bearing

▶ Popular item

<sup>1)</sup> For additional bearing data → [product table, page 856](#)

<sup>2)</sup> For additional adapter sleeve data → [product table, page 1072](#)

Principal dimensions			Abutment and fillet dimensions			Mass Bearing + sleeve	Designations Bearing <sup>1)</sup>	Sleeve <sup>2)</sup>
d <sub>1</sub>	D	B	d <sub>a</sub> max.	d <sub>b</sub> min.	B <sub>a</sub> min.			
mm			mm			kg	–	
115	230	64	171	138	8	14	C 2226 K C 2326 K/VE240	H 3126 L H 2326
	280	93	201	142	8	31,5		
125	250	68	191	149	8	17,5	▶ C 2228 K	H 3128 L
135	225	56	190	158	8	11,5	C 3030 KV C 3130 K C 2230 K	H 3030 H 3130 L H 3130 L
	250	80	196	160	8	20		
	270	73	202	160	15	23		
140	270	86	208	170	8	27	C 3132 K C 3232 K	H 3132 L H 2332 L
	290	104	218	174	18	36,5		
150	310	86	233	180	10	35	C 2234 K	H 3134 L
160	280	74	223	189	9	23	C 3036 K C 3136 K C 3236 K	H 3036 H 3136 L H 2336
	300	96	231	191	8	34		
	320	112	249	195	22	47		
170	290	75	238	199	10	24	C 3038 K C 3138 KV C 2238 K	H 3038 H 3138 H 3138
	320	104	267	202	9	45		
	340	92	254	202	21	43		
180	310	82	250	210	10	30	C 3040 K ▶ C 3140 K	H 3040 H 3140
	340	112	264	212	9	50,5		
200	340	90	274	231	10	37	▶ C 3044 K C 3144 K C 2244 K	OH 3044 H OH 3144 HTL OH 3144 H
	370	120	290	233	10	64		
	400	108	298	233	22	69		
220	360	92	293	251	11	42,5	C 3048 K C 3148 K	OH 3048 H OH 3148 HTL
	400	128	309	254	11	77		
240	400	104	326	272	11	59	C 3052 K ▶ C 3152 K	OH 3052 H OH 3152 HTL
	440	144	341	276	11	105		
260	420	106	352	292	12	65	C 3056 K C 3156 K	OH 3056 H OH 3156 HTL
	460	146	363	296	12	115		
280	460	118	376	313	12	91	C 3060 KM C 3160 K	OH 3060 H OH 3160 H
	500	160	392	318	12	150		
300	480	121	398	334	13	95	C 3064 KM C 3164 KM	OH 3064 H OH 3164 H
	540	176	411	338	13	190		
320	520	133	425	355	14	125	C 3068 KM C 3168 KM	OH 3068 H OH 3168 H
	580	190	446	360	14	235		
340	480	90	409	372	14	73	C 3972 KM C 3072 KM C 3172 KM	OH 3972 HE OH 3072 H OH 3172 H
	540	134	448	375	14	135		
	600	192	464	380	14	250		
360	560	135	462	396	15	145	C 3076 KM C 3176 KMB	OH 3076 H OH 3176 HE
	620	194	445	401	15	290		
380	540	106	461	413	15	105	C 3980 KM C 3080 KM C 3180 KM	OH 3980 HE OH 3080 H OH 3180 H
	600	148	486	417	15	175		
	650	200	525	421	15	345		
400	560	106	484	433	15	106	C 3984 KM C 3084 KM C 3184 KM	OH 3984 HE OH 3084 H OH 3184 H
	620	150	513	437	16	180		
	700	224	544	443	16	395		
410	650	157	489	458	17	250	C 3088 KMB C 3188 KMB	OH 3088 HE OH 3188 HE
	720	226	521	463	17	475		

SKF Explorer bearing

▶ Popular item

<sup>1)</sup> For additional bearing data → [product table, page 856](#)

<sup>2)</sup> For additional adapter sleeve data → [product table, page 1072](#)



## 10.2 CARB toroidal roller bearings on an adapter sleeve

$d_1$  430 – 1 000 mm

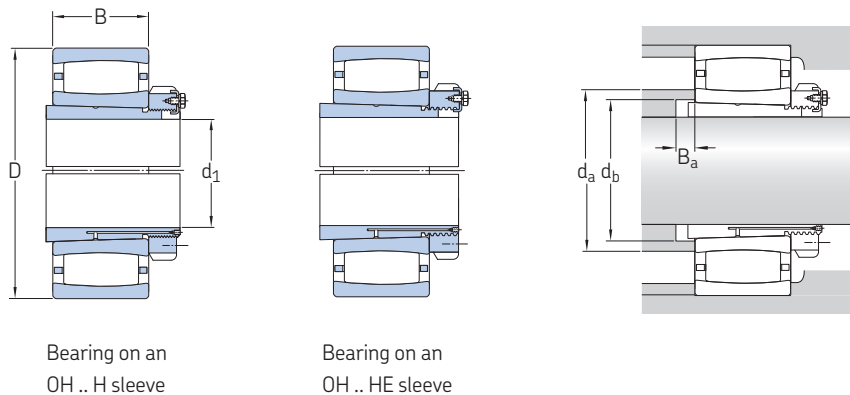

Bearing on an  
OH .. H sleeve

Bearing on an  
OH .. HE sleeve

Principal dimensions			Abutment and fillet dimensions			Mass Bearing + sleeve	Designations Bearing <sup>1)</sup>	Sleeve <sup>2)</sup>
$d_1$	D	B	$d_a$ max.	$d_b$ min.	$B_a$ min.			
mm			mm			kg	–	
430	680	163	570	478	17	270	C 3092 KM	OH 3092 H
	760	240	603	484	17	540	C 3192 KM	OH 3192 H
450	700	165	586	499	18	275	C 3096 KM	OH 3096 H
	790	248	577	505	18	620	C 3196 KMB	OH 3196 HE
470	670	128	580	516	18	195	C 39/500 KM	OH 39/500 HE
	830	264	654	527	18	690	C 31/500 KM	OH 31/500 H
500	780	185	638	551	20	390	C 30/530 KM	OH 30/530 H
	870	272	685	558	20	770	C 31/530 KM	OH 31/530 H
530	750	140	648	577	20	260	C 39/560 KM	OH 39/560 HE
	820	195	696	582	20	440	C 30/560 KM	OH 30/560 H
	980	300	704	629	22	1 100	C 31/600 KMB	OH 31/600 HE
560	870	200	728	623	22	520	C 30/600 KM	OH 30/600 H
600	850	165	723	650	22	420	C 39/630 KM	OH 39/630 HE
	920	212	759	654	22	635	C 30/630 KM	OH 30/630 H
	1 030	315	740	663	22	1 280	C 31/630 KMB	OH 31/630 HE
630	980	230	820	696	22	750	C 30/670 KM	OH 30/670 H
	1 090	336	791	705	22	1 550	C 31/670 KMB	OH 31/670 HE
670	950	180	797	732	26	520	C 39/710 KM	OH 39/710 HE
	1 030	236	853	736	26	865	C 30/710 KM	OH 30/710 H
	1 150	345	841	745	26	1 800	C 31/710 KMB	OH 31/710 HE
710	1 000	185	856	772	26	590	C 39/750 KM	OH 39/750 HE
	1 090	250	852	778	26	1 000	C 30/750 KMB	OH 30/750 HE
	1 220	365	883	787	26	2 150	C 31/750 KMB	OH 31/750 HE
750	1 150	258	905	829	28	1 150	C 30/800 KMB	OH 30/800 HE
800	1 120	200	963	872	28	785	C 39/850 KM	OH 39/850 HE
	1 220	272	963	880	28	1 050	C 30/850 KMB	OH 30/850 HE
850	1 280	280	1 003	931	30	1 520	C 30/900 KMB	OH 30/900 HE
950	1 580	462	1 189	1 047	33	4 300	C 31/1000 KMB	OH 31/1000 HE
1 000	1 400	250	1 164	1 087	33	1 610	C 39/1060 KMB	OH 39/1060 HE

SKF Explorer bearing

<sup>1)</sup> For additional bearing data → product table, page 856

<sup>2)</sup> For additional adapter sleeve data → product table, page 1072





### 10.3 CARB toroidal roller bearings on a withdrawal sleeve

$d_1$  35 – 340 mm

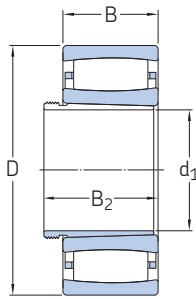

Bearing on an  
AH sleeve

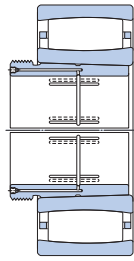

Bearing on an  
AOH sleeve

Principal dimensions				Mass Bearing + sleeve	Designations Bearing <sup>1)</sup>	Sleeve <sup>2)</sup>
$d_1$	D	B	$B_2^{3)}$ ≈			
mm				kg	–	
35	80	23	32	0,59	<b>C 2208 KTN9</b>	AH 308
40	85	23	34	0,67	▶ <b>C 2209 KTN9</b>	AH 309
45	90	23	38	0,72	▶ <b>C 2210 KTN9</b>	AHX 310
50	100	25	40	0,95	▶ <b>C 2211 KTN9</b> <b>C 2211 KV</b>	AHX 311
	100	25	40	0,97		AHX 311
55	110	28	43	1,3	▶ <b>C 2212 KTN9</b> <b>C 2212 KV</b>	AHX 312
	110	28	43	1,35		AHX 312
60	120	31	45	1,6	▶ <b>C 2213 KTN9</b> <b>C 2213 KV</b>	AH 313 G
	120	31	45	1,7		AH 313 G
65	125	31	47	1,7	<b>C 2214 KTN9</b> <b>C 2314 K</b>	AH 314 G
	150	51	68	4,65		AHX 2314 G
70	130	31	49	1,9	▶ <b>C 2215 K</b> <b>C 2215 KV</b> ▶ <b>C 2315 K</b>	AH 315 G
	130	31	49	1,95		AH 315 G
	160	55	72	5,65		AHX 2315 G
75	140	33	52	2,35	▶ <b>C 2216 K</b> <b>C 2216 KV</b> ▶ <b>C 2316 K</b>	AH 316
	140	33	52	2,45		AH 316
	170	58	75	6,75		AHX 2316
80	150	36	56	3	▶ <b>C 2217 K</b> ▶ <b>C 2317 K</b>	AHX 317
	180	60	78	7,9		AHX 2317
85	160	40	57	3,75	▶ <b>C 2218 K</b> <b>C 2318 K</b>	AHX 318
	190	64	83	9		AHX 2318
90	200	67	89	11	<b>C 2319 K</b>	AHX 2319
95	180	46	63	5,3	▶ <b>C 2220 K</b> ▶ <b>C 2320 K</b>	AHX 320
	215	73	94	13,5		AHX 2320
105	200	53	72	7,65	▶ <b>C 2222 K</b>	AHX 3122
115	180	60	82	5,65	<b>C 4024 K30V/VE240</b> <b>C 4024 K30V</b> ▶ <b>C 3224 K</b>	AH 24024
	180	60	82	6,2		AH 24024
	215	76	94	13		AHX 3224 G

#### SKF Explorer bearing

▶ Popular item

<sup>1)</sup> For additional bearing data → [product table, page 856](#)

<sup>2)</sup> For additional withdrawal sleeve data → [skf.com/go/17000-24-1](http://skf.com/go/17000-24-1)

<sup>3)</sup> Width before the sleeve is driven into the bearing bore

Principal dimensions				Mass Bearing + sleeve	Designations Bearing <sup>1)</sup>	Sleeve <sup>2)</sup>
d <sub>1</sub>	D	B	B <sub>2</sub> <sup>3)</sup> ≈			
mm				kg	–	
125	200	69	93	8,7	C 4026 K30	AH 24026
	200	69	93	8,9	C 4026 K30V	AH 24026
	230	64	82	12	▶ C 2226 K	AHX 3126
	280	93	119	29	C 2326 K/VE240	AHX 2326 G
135	210	69	93	9,5	C 4028 K30V	AH 24028
	250	68	88	15,5	▶ C 2228 K	AHX 3128
145	225	56	77	8,9	C 3030 KV	AHX 3030
	225	75	101	11,5	C 4030 K30V	AH 24030
	250	80	101	16,5	C 3130 K	AHX 3130 G
	270	73	101	19	C 2230 K	AHX 3130 G
150	240	80	106	14,5	C 4032 K30	AH 24032
	240	80	106	15	C 4032 K30V	AH 24032
	270	86	108	23	C 3132 K	AH 3132 G
	290	104	130	31	C 3232 K	AH 3232 G
160	260	90	117	20	C 4034 K30V	AH 24034
	310	86	109	31	C 2234 K	AH 3134 G
170	280	74	98	19	C 3036 K	AH 3036
	300	96	122	30	▶ C 3136 K	AH 3136 G
	320	112	146	41,5	C 3236 K	AH 3236 G
180	290	75	102	20,5	C 3038 K	AH 3038 G
	320	104	131	39	C 3138 KV	AH 3138 G
	340	92	117	38	C 2238 K	AH 2238 G
190	310	82	108	25,5	C 3040 K	AH 3040 G
	340	112	140	45,5	▶ C 3140 K	AH 3140
200	340	90	117	36	▶ C 3044 K	AOH 3044 G
	340	118	152	48	C 4044 K30V	AOH 24044
	370	120	151	60	▶ C 3144 K	AOH 3144
	400	108	136	65,5	C 2244 K	AOH 2244
220	360	92	123	39,5	C 3048 K	AOH 3048
	400	128	161	75	▶ C 3148 K	AOH 3148
240	400	104	135	55,5	C 3052 K	AOH 3052
	440	144	179	102	▶ C 3152 K	AOH 3152 G
260	420	106	139	61	C 3056 K	AOH 3056
	460	146	183	110	C 3156 K	AOH 3156 G
280	460	118	153	84	C 3060 KM	AOH 3060
	460	160	202	110	C 4060 K30M	AOH 24060 G
	500	160	200	140	C 3160 K	AOH 3160 G
300	480	121	157	93	C 3064 KM	AOH 3064 G
	540	176	217	185	C 3164 KM	AOH 3164 G
320	520	133	171	120	C 3068 KM	AOH 3068 G
	580	190	234	230	C 3168 KM	AOH 3168 G
340	540	134	176	125	C 3072 KM	AOH 3072 G
	600	192	238	245	C 3172 KM	AOH 3172 G

**SKF Explorer bearing**

▶ Popular item

<sup>1)</sup> For additional bearing data → [product table, page 856](#)

<sup>2)</sup> For additional withdrawal sleeve data → [skf.com/go/17000-24-1](http://skf.com/go/17000-24-1)

<sup>3)</sup> Width before the sleeve is driven into the bearing bore



### 10.3 CARB toroidal roller bearings on a withdrawal sleeve

$d_1$  360 – 950 mm

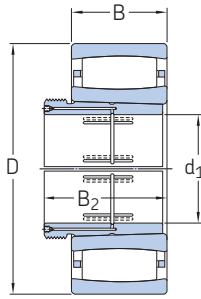

Principal dimensions				Mass Bearing + sleeve	Designations Bearing <sup>1)</sup>	Sleeve <sup>2)</sup>
$d_1$	D	B	$B_2^{3)}$ ≈			
mm				kg	–	
360	560	135	180	130	C 3076 KM	AOH 3076 G
	620	194	242	260	C 3176 KMB	AOH 3176 G
380	600	148	193	165	C 3080 KM	AOH 3080 G
	650	200	250	310	C 3180 KM	AOH 3180 G
400	620	150	196	175	C 3084 KM	AOH 3084 G
	700	224	276	380	C 3184 KM	AOH 3184 G
420	650	157	205	215	C 3088 KMB	AOHX 3088 G
	720	226	281	405	C 3188 KMB	AOHX 3188 G
	720	280	332	510	C 4188 K30MB	AOH 24188
440	680	163	213	230	C 3092 KM	AOHX 3092 G
	760	240	296	480	C 3192 KM	AOHX 3192 G
	760	300	355	621	C 4192 K30MB	AOH 24192
460	700	165	217	245	C 3096 KM	AOHX 3096 G
	790	248	307	545	C 3196 KMB	AOHX 3196 G
480	830	264	325	615	C 31/500 KM	AOHX 31/500 G
500	780	185	242	355	C 30/530 KM	AOH 30/530
	870	272	337	720	C 31/530 KM	AOH 31/530
530	820	195	252	415	C 30/560 KM	AOHX 30/560
	920	355	417	989	C 41/560 K30MB	AOH 241/560 G
570	870	200	259	460	C 30/600 KM	AOHX 30/600
	980	300	369	990	C 31/600 KMB	AOHX 31/600
	980	375	439	1 270	C 41/600 K30MB	AOHX 241/600
600	920	212	272	555	C 30/630 KM	AOH 30/630
	1 030	315	389	1 180	C 31/630 KMB	AOH 31/630
630	980	230	294	705	C 30/670 KM	AOH 30/670
	1 090	336	409	1 410	C 31/670 KMB	AOHX 31/670
670	1 030	236	302	780	C 30/710 KM	AOHX 30/710
	1 030	315	386	1 010	C 40/710 K30M	AOH 240/710 G
	1 150	345	421	1 600	C 31/710 KMB	AOHX 31/710
710	1 090	250	316	920	C 30/750 KMB	AOH 30/750
	1 220	365	441	1 930	C 31/750 KMB	AOH 31/750

#### SKF Explorer bearing

<sup>1)</sup> For additional bearing data → [product table, page 856](#)

<sup>2)</sup> For additional withdrawal sleeve data → [skf.com/go/17000-24-1](https://skf.com/go/17000-24-1)

<sup>3)</sup> Width before the sleeve is driven into the bearing bore

Principal dimensions				Mass Bearing + sleeve	Designations Bearing <sup>1)</sup>	Sleeve <sup>2)</sup>
d <sub>1</sub>	D	B	B <sub>2</sub> <sup>3)</sup> ≈			
mm				kg	–	
750	1 150	258	326	1 060	<a href="#">C 30/800 KMB</a>	AOH 30/800
800	1 220	272	343	1 280	<a href="#">C 30/850 KMB</a>	AOH 30/850
850	1 280	280	355	1 400	<a href="#">C 30/900 KMB</a>	AOH 30/900
950	1 580	462	547	3 950	<a href="#">C 31/1000 KMB</a>	AOH 31/1000

**SKF Explorer bearing**
<sup>1)</sup> For additional bearing data → [product table, page 856](#)
<sup>2)</sup> For additional withdrawal sleeve data → [skf.com/go/17000-24-1](#)
<sup>3)</sup> Width before the sleeve is driven into the bearing bore